

AV1 and AV2

Characterizable pneumatic and electro-pneumatic positioners



Pneumatic and electro-pneumatic positioners built on proven performance for demanding process conditions

Measurement made easy

— Characterizable analog positioners

Introduction

AV characterizable pneumatic positioners are control devices that satisfy a wide range of applications. They provide fast, sensitive and accurate positioning of pneumatic single- or double-acting, linear or rotary motion actuators. A mechanical connection from the actuator to a position feedback cam in the positioner establishes actual position. Three characterized segments on one cam provide application flexibility by establishing various relationships between input signal and actuator position. The relationships provided by the segments are square root, linear and square.

Trademarks and Registrations

Registrations and trademarks used in this document include:

® Delrin	Registered trademark of E.I. DuPont de Nemours Company, Incorporated
® Dow Corning	Registered trademark of Dow Corning Corporation
® Lexan	Registered trademark of General Electric Company, GE Plastics Division
® Monel	Registered trademark of International Nickel Company
® Noryl	Registered trademark of General Electric Company, GE Plastics Division
® PowerRac	Registered trademark of DeZurik, a Unit of General Signal
® Rynite	Registered trademark of E.I. DuPont de Nemours Company, Incorporated
® Teflon	Registered trademark of E.I. DuPont de Nemours Company, Incorporated
® Valox	Registered trademark of General Electric Company, GE Plastics Division
® Viton	Registered trademark of E.I. DuPont de Nemours Company, Incorporated

WARNING notices as used in this manual apply to hazards or unsafe practices which could result in personal injury or death.

CAUTION notices apply to hazards or unsafe practices which could result in property damage.

NOTES highlight procedures and contain information which assist the operator in understanding the information contained in this manual.

All software, including design, appearance, algorithms and source codes, is copyrighted by ABB Inc. and is owned by ABB Inc. or its suppliers.

WARNING

POSSIBLE PROCESS UPSETS. Maintenance must be performed only by qualified personnel and only after securing equipment controlled by this product. Adjusting or removing this product while it is in the system may upset the process being controlled. Some process upsets may cause injury or damage.

NOTICE

The information contained in this document is subject to change without notice.

ABB Inc., its affiliates, employees, and agents, and the authors of and contributors to this publication specifically disclaim all liabilities and warranties, express and implied (including warranties of merchantability and fitness for a particular purpose), for the accuracy, currency, completeness, and/or reliability of the information contained herein and/or for the fitness for any particular use and/or for the performance of any material and/or equipment selected in whole or part with the user of/or in reliance upon information contained herein. Selection of materials and/or equipment is at the sole risk of the user of this publication.

This document contains proprietary information of ABB Inc., and is issued in strict confidence. Its use, or reproduction for use, for the reverse engineering, development or manufacture of hardware or software described herein is prohibited. No part of this document may be photocopied or reproduced without the prior written consent of ABB Inc..

Table of Contents

	<i>Page</i>
SECTION 1 - INTRODUCTION	1-1
OVERVIEW	1-1
INTENDED USER	1-1
DESCRIPTION	1-1
Performance Series Option	1-2
Explosionproof I/P Option	1-3
NEMA 4X Option	1-3
APPLICATION	1-3
FEATURES	1-3
INSTRUCTION CONTENT	1-5
REFERENCE DOCUMENTS	1-6
NOMENCLATURE	1-6
SPECIFICATIONS	1-7
SECTION 2 - DESCRIPTION AND OPERATION	2-1
INTRODUCTION	2-1
FUNCTIONAL OPERATION	2-2
SECTION 3 - INSTALLATION	3-1
INTRODUCTION	3-1
UNPACKING AND INSPECTION	3-1
ENCLOSURE CLASSIFICATION	3-2
MOUNTING CONSIDERATIONS	3-2
MOUNTING TYPE AV POSITIONERS	3-4
TUBING CONNECTIONS	3-8
Air Supply Pressure	3-8
Air Supply Filtering	3-8
Air Supply Quality (Recommended)	3-9
Tubing Connections	3-9
WIRING TYPE AV2 POSITIONER	3-10
WIRING TYPE AV1 POSITIONER	3-13
RADIO FREQUENCY INTERFERENCE	3-15
WIRING REQUIREMENTS	3-15
SECTION 4 - CALIBRATION	4-1
INTRODUCTION	4-1
CALIBRATION	4-1
Zero Adjustment	4-1
Span Adjustment	4-3
CALIBRATION FOR PARTICULAR APPLICATION	4-3
Zero Adjustment	4-4
Span Adjustment	4-4
GAIN AND SPEED ADJUSTMENTS	4-5
Gain Adjustment	4-5
Speed Adjustment	4-6
ORIFICE	4-6
PILOT VALVE STROKE ADJUSTMENT	4-6
TROUBLESHOOTING CALIBRATION ADJUSTMENTS	4-8
SECTION 5 - OPERATING PROCEDURES	5-1
INTRODUCTION	5-1

Table of Contents (continued)

	<i>Page</i>
EQUALIZING AND AIR SUPPLY SHUTOFF VALVE.....	5-1
Transfer from Automatic to Manual Operation	5-1
Transfer from Manual to Automatic Operation	5-1
SECTION 6 - TROUBLESHOOTING.....	6-1
INTRODUCTION	6-1
SECTION 7 - MAINTENANCE.....	7-1
INTRODUCTION	7-1
PREVENTIVE MAINTENANCE SCHEDULE	7-1
PREVENTIVE MAINTENANCE PROCEDURES	7-2
MANIFOLD FILTERS	7-2
SECTION 8 - REPAIR AND REPLACEMENT.....	8-1
INTRODUCTION	8-1
REPLACEMENT PROCEDURES	8-1
Manifold	8-1
Gain Hinge Spring	8-2
Pilot Valve Assembly	8-3
I/P Converter	8-4
Cam	8-5
Diaphragm Assembly	8-5
DIAPHRAGM ASSEMBLY REMOVAL.....	8-6
DIAPHRAGM ASSEMBLY REPLACEMENT	8-6
PILOT VALVE STROKE ADJUSTMENT.....	8-7
SECTION 9 - SUPPORT SERVICES.....	9-1
INTRODUCTION	9-1
RECOMMENDED SPARE PARTS.....	9-1
ADDITIONAL SPARE PARTS.....	9-3
APPENDIX A - POSITION TRANSMITTERS.....	A-1
INTRODUCTION	A-1
DESCRIPTION AND OPERATION	A-1
CALIBRATION.....	A-2
Calibrating the Potentiometric Position Transmitter	A-2
POTENTIOMETRIC APPLICATION EXAMPLE	A-3
CALIBRATING THE POTENTIOMETRIC EXAMPLE	A-4
Calibrating the 4 to 20-mA Position Transmitter.....	A-6
APPENDIX B - QUICK START.....	B-1
INTRODUCTION	B-1
PRODUCT IDENTIFICATION (NOMENCLATURE).....	B-1
MOUNTING THE POSITIONER.....	B-2
TUBING CONNECTIONS.....	B-5
TYPE AV2 POSITIONER WIRING	B-8
TYPE AV1 POSITIONER WIRING	B-10
CALIBRATION.....	B-11

Table of Contents (continued)

	<i>Page</i>
APPENDIX C - CAM CHARACTERIZATION	C-1
INTRODUCTION	C-1
CAM CHARACTERIZATION	C-1
CAM SELECTION	C-3
CAM SHAPING	C-5
APPENDIX D - TYPE AV1 PNEUMATIC POSITION TRANSMITTER.....	D-1
INTRODUCTION	D-1
DESCRIPTION	D-1
INSTALLATION	D-2
CALIBRATION.....	D-3

List of Figures

<i>No.</i>	<i>Title</i>	<i>Page</i>
1-1.	Capacity (Exhaust to Atmosphere).....	1-9
1-2.	Air Consumption	1-10
1-3.	Output Air Flow vs. Error Signal — Standard and Performance Series	1-10
1-4.	Expanded First Quadrant View	1-11
2-1.	Operation Diagram	2-1
2-2.	Block Diagram	2-1
3-1.	External and Mounting Dimensions.....	3-3
3-2.	Electrical Connections.....	3-4
3-3.	Drive Arm Connections.....	3-4
3-4.	Drive Shaft Variations.....	3-5
3-5.	Mounting Using Linkage (Typical)	3-5
3-6.	Mounting Using Direct Coupling (Typical)	3-6
3-7.	Cam.....	3-7
3-8.	Cam Roller Alignment.....	3-8
3-9.	Port Locations	3-9
3-10.	Direct Acting, Top Loaded, Single Acting Tubing Example.....	3-11
3-11.	Reverse Acting, Top Loaded, Single Acting Tubing Example.....	3-12
3-12.	Direct Acting, Bottom Loaded, Single Acting Tubing Example	3-12
3-13.	Reverse Acting, Bottom Loaded, Single Acting Tubing Example	3-13
3-14.	Double Acting Tubing Example	3-14
3-15.	Wiring Connections	3-14
4-1.	Calibration Adjustments.....	4-2
4-2.	Cam Roller Alignment.....	4-3
4-3.	Zero Adjustment Graph	4-4
4-4.	Span Adjustment Graph	4-5
4-5.	Pilot Valve Adjustment.....	4-7
4-6.	Speed Adjustment Screws	4-7
4-7.	I/P Adjustment	4-9
7-1.	Positioner with Manifold	7-3
7-2.	Manifold with Filter Cover Removed	7-3
8-1.	Positioner with Manifold	8-2
8-2.	Manifold O-Rings.....	8-3

List of Figures (continued)

<i>No.</i>	<i>Title</i>	<i>Page</i>
8-3.	Pilot Valve Measurement for Maximum Speed.....	8-8
8-4.	Stroke Adjustment Screws.....	8-8
9-1.	Mounting Kits.....	9-6
9-2.	Bypass Valve Assembly.....	9-8
9-3.	Type AV1 Positioner	9-11
9-4.	Type AV2 Positioner (Page 1 of 2).....	9-16
9-4.	Type AV2 Positioner (Page 2 of 2).....	9-17
A-1.	Terminal Block Connections	A-2
A-2.	Schematic Diagram	A-4
A-3.	Potentiometric Position Transmitter (Exploded View).....	A-5
A-4.	Calibration Features for 4 to 20-mA Position Transmitter.....	A-6
A-5.	4 to 20-mA Position Transmitter (Exploded View)	A-7
B-1.	Mounting Using Linkage (Typical)	B-3
B-2.	Mounting Using Direct Coupling (Typical)	B-3
B-3.	Drive Arm Connections.....	B-4
B-4.	Cam Roller Alignment.....	B-4
B-5.	Port Locations.....	B-5
B-6.	Direct Acting, Top Loaded, Single Acting Tubing Example	B-6
B-7.	Reverse Acting, Top Loaded, Single Acting Tubing Example	B-6
B-8.	Direct Acting, Bottom Loaded, Single Acting Tubing Example	B-7
B-9.	Reverse Acting, Bottom Loaded, Single Acting Tubing Example	B-7
B-10.	Double Acting Tubing Example.....	B-8
B-11.	Wiring Connections	B-9
B-12.	Calibration Adjustments.....	B-9
C-1.	Cam A, Square Root Relationship.....	C-1
C-2.	Cam B, Linear Relationship.....	C-2
C-3.	Cam C, Square Relationship	C-2
C-4.	Regulated Device Characteristics	C-4
C-5.	Desired Control.....	C-4
C-6.	Cam Characteristics	C-5
C-7.	Graph to Cam Data Transfer	C-7
D-1.	Pneumatic Position Transmitter Kit.....	D-2

List of Tables

<i>No.</i>	<i>Title</i>	<i>Page</i>
1-1.	Reference Documents.....	1-6
1-2.	Nomenclature	1-6
1-3.	Type AV1/2 Positioner Specifications.....	1-7
1-4.	Type AV ____1__ Potentiometric Position Transmitter Specifications	1-11
1-5.	Type AV ____2__ 4 to 20-mA Position Transmitter Specifications	1-11
1-6.	Agency Approvals.....	1-12
1-7.	Accessories	1-12
1-8.	Rotary Actuator Retrofit Mounting Kits	1-13
1-9.	Speed Control Orifices	1-13
1-10.	Pressure Gages.....	1-13
1-11.	Supply Air Regulators with Gages.....	1-13

List of Tables (continued)

No.	Title	Page
1-12.	Supply Air Filters	1-14
1-13.	Component Material List	1-14
3-1.	Cam Characteristics	3-7
4-1.	Gain Hinge Springs	4-5
6-1.	Positioner Errors.....	6-1
7-1.	Preventive Maintenance Schedule.....	7-1
9-1.	Shutoff Valve Kit No. 258270_1	9-1
9-2.	AV Diaphragm Assembly Kit No. 258486_1.....	9-1
9-3.	AV Diaphragm Assembly Kit No. 258486_2	9-2
9-4.	Filter Replacement Kit No. 258487_1	9-2
9-5.	Pilot Valve Assembly Kit No. 258488_1	9-2
9-6.	Pilot Valve Assembly Kit No. 258488_2.....	9-2
9-7.	Pilot Valve Assembly Kit No. 258488_3.....	9-2
9-8.	Pilot Valve Assembly Kit No. 258488_4.....	9-3
9-9.	Cam.....	9-3
9-10.	I/P Assembly Kit No. 258477_1.....	9-3
9-11.	Gain Hinge Springs	9-3
9-12.	Manifold Assembly Kit No. 258491_1	9-3
9-13.	Cam Follower Arm Kit No. 258544_1	9-4
9-14.	Cover Assembly Kit No. 258545_1	9-4
9-15.	Cover Assembly Kit No. 258545_1	9-4
9-16.	Gage Block Assembly Kit No. 258569_1	9-4
9-17.	Gage Block Assembly Kit No. 258569_3	9-4
9-18.	Potentiometer	9-4
9-19.	4 to 20-mA Position Transmitter Circuit Board	9-5
9-20.	Positioner Mounting Kit Number 5327321_121.....	9-5
9-21.	Positioner Mounting Kit Number 5327321_131.....	9-5
9-22.	Positioner Mounting Kit Number 5327321_141 (for use on Fisher Actuators)	9-6
9-23.	Rotary Actuator Retrofit Mounting Kits	9-7
9-24.	Bypass Valve Assembly (Optional)	9-7
9-25.	Type AV1 Positioner Parts List.....	9-9
9-26.	Input Signal Parts Reference for Type AV1 Positioners.....	9-10
9-27.	Cam Selection and Manifold/Gage Block Parts Reference for Type AV1 Positioners.....	9-10
9-28.	Shaft Position Transmitter Parts Reference for Type AV1 Positioners	9-12
9-29.	Drive Shaft Parts Reference for Type AV1 Positioners.....	9-12
9-30.	Type AV2 Positioner Parts List	9-12
9-31.	Cam and Drive Shaft Parts Reference for Type AV2 Positioners	9-13
9-32.	Manifold/Gage Block Parts Reference for Type AV2 Positioners	9-15
9-33.	Shaft Position Transmitter Parts Reference for Type AV2 Positioners	9-15
9-34.	Conversion Kits	9-17
A-1.	Potentiometric Position Transmitter Parts List	A-5
A-2.	4 to 20-mA Position Transmitter Parts List.....	A-7
B-1.	Nomenclature	B-1
B-2.	Calibration Procedures.....	B-11
C-1.	Control Signal Pressure Conversions (AV1)	C-3
C-2.	Input to Output I/P Converter Relationships (AV2).....	C-3
D-1.	Pneumatic Position Transmitter Kit (258492_1).....	D-2

Read First

WARNING

INSTRUCTION MANUALS

Do not install, maintain or operate this equipment without reading, understanding and following the proper factory-supplied instructions and manuals, otherwise injury or damage may result.

RETURN OF EQUIPMENT

All equipment being returned to the factory for repair must be free of any hazardous materials (acids, alkalis, solvents, etc.). A Material Safety Data Sheet (MSDS) for all process liquids must accompany returned equipment. Contact the factory for authorization prior to returning equipment.

Read these instructions before starting installation;
save these instructions for future reference.

Contacting the Factory . . .

Should assistance be required with any of the company's products, contact the following:

Telephone:

24-Hour Call Center
1-800-HELP-365

E-Mail:

ins.techsupport@us.abb.com

SECTION 1 - INTRODUCTION

OVERVIEW

This section covers the following topics:

- Positioner description.
- Positioner application.
- Features of positioners.
- Instruction content.
- How to use this instruction.
- Positioner nomenclature.
- Positioner specifications.
- Position transmitter specifications.
- Agency approvals.
- Accessories.
- Mounting kits.

NOTE: [Appendix B](#) provides a quick start guide for the Type AV positioner. It is intended for control engineers having experience in the use and application of pneumatic positioners. The quick start guide highlights the major points of installation and calibration. Detailed installation and calibration information is contained in [Section 3](#) and [Section 4](#) respectively.

INTENDED USER

The information in this instruction is a guide for technical personnel responsible for installation, calibration, operation, maintenance and repair of the positioner.

DESCRIPTION

The Type AV1 and Type AV2 positioners are control devices that satisfy a wide range of applications. They provide fast, sensitive and accurate positioning of pneumatic single or double acting actuators.

The Type AV1 positioner receives an external pneumatic signal and converts it to a pneumatic output. The Type AV2 positioner accepts a four to 20-milliamp current that is applied to an I/P (current to pneumatic) converter, located inside the housing, to generate an internal signal pressure.

If a loss of signal occurs, the Type AV2 positioner goes to the four-milliamp position. The Type AV1 positioner goes to the 3 psi position.

A mechanical connection from the actuator (i.e., cylinder, valve, etc.) to the position feedback cam in the positioner establishes actual position. Three characterized segments on the cam provide application flexibility by establishing various relationships between the input signal and the actuator position. The characterized curves on the cam provide:

- Square root relationship.
- Linear relationship.
- Square characteristic.

Using the zero, span and gain adjustments and the cam, the actuator can respond with characteristics specific to an application.

An optional manifold assembly provides an integral shutoff and equalizing valve that can be used to isolate the positioner from an actuator, allowing manual override without removing the positioner from the process (required on double acting actuators with manual override). The manifold also provides gage ports and disposable filter cartridges that insure fast servicing and minimum downtime.

An optional gage block provides gage ports for mounting pressure gages. There are three gage ports on the block: One for instrument indication (internal input signal) and two for output indication. The gage block does not provide filters or means of isolating the positioner from the actuator. Installation of a supply gage is possible in the supply line (piping by customer).

Both positioners can be equipped with either an optional potentiometric or a four to 20-milliamp position transmitter that provides additional control features.

Performance Series Option

The Type AV positioner performance series provides a high flow gain pilot valve body by adding a P in the ninth nomenclature position. This high gain pilot valve body has square ports that provide a maximized air flow for a small motion of the pilot valve stem. A relatively small error signal can therefore cause a relatively large change in output air flow to the actuator. This feature is useful when driving larger actuators that might otherwise be insensitive or slow to respond to small signal changes.

Compared to other positioners on the market, the standard Type AV positioners have a high delivery capacity. The performance series increases this delivery capacity even more. The flow gain curves shown in Figures 1-3 and 1-4 show output air flow versus input error signal for the standard and high gain performance series positioners.

Figures 1-3 and 1-4 show that the large signal maximum air flow for both the standard and performance series positioners is about the same. The performance series positioners achieve maximum flow capacity at a much smaller error signal.

NOTE: ABB does not recommend using a performance series positioner on a small actuator, as it could cause instability.

Explosionproof I/P Option

The Type AV27 positioner employs an explosionproof I/P converter that is mounted to an adapter block manifold. The adapter block manifold is bolted to the outside of the main positioner housing. The unit is a Type AV12 positioner with the electric to pneumatic (four to 20-milliamp to 20.7 to 103.4-kilopascal (3.0 to 15.0-pounds per square inch gage)) conversion occurring within the externally mounted I/P converter.

The four to 20-milliamp input signal wires shall be connected through an explosionproof conduit entrance on the I/P converter. If no electrical connections are made within the main housing, the entire positioner can be considered suitable for application in the hazardous locations shown on the I/P label.

Refer to Figure 3-1 for the external and mounting dimensions of the Type AV27 positioner.

NEMA 4X Option

The Type AV____N positioner comes with a NEMA 4X housing. To maintain the NEMA 4X classification, the positioner shall be installed per drawing C258567 and suitable piping shall be attached to the vent opening and vented in a manner to preclude the entrance of water under pressure, as from a hose. Additionally, the conduit connections shall be suitable for a NEMA 4X rating.

APPLICATION

The Type AV1 and Type AV2 Characterizable Pneumatic Positioners control the position of a pneumatic actuator.

FEATURES

- **Trouble-Free Operation.** Proven pilot valve that is quickly removable, provides less downtime, lower maintenance costs, increased reliability and extended performance.
- **Compact Rugged Design.** Die cast aluminum housing, beam, spring arm, follower arm and 303 stainless steel pilot

valve provide long life and maximum environmental protection. The compact housing increases mounting flexibility.

- **Characterizable Output.** Large positioning cam can be shaped to provide desired relationship between the input signal and the actuator position.
- **Accurate Calibration.** Independent zero and span adjustments eliminate interaction and provide fast and accurate calibration.
- **Simplified Reverse Operation.** Action can be changed in the field by changing cams and reversing O1 and O2 connections. The reverse acting cam is conveniently located on the inside of the front cover.
- **Highly Visible Position Status Indicator.** A fluorescent orange position indicator is visible through a polycarbonate window, providing fast indication of actuator position.
- **Vent Design Allows Natural Gas Operation.** Vent pipe arrangement permits operation using natural gas.
- **Split Range Service.** Split range capability allows sequencing of multiple actuators using a single control signal.
- **Adjustable Gain.** Two levels of gain are possible by changing the hinge springs supplied with the positioner.
- **Adaptable Usage.** The positioner can control both single and double acting, linear and rotary type actuators.
- **High Capacity.** More than 0.65 cubic meters per minute (23 standard cubic feet per minute) can be supplied or exhausted at 482.6 kilopascals (70.0 pounds per square inch gage) supply pressure (Fig. 1-1).
- **Continuously Adjustable Span and Zero for Each Stroke Level.** Capable of 100-percent stroke for 50-percent signal span or 50-percent stroke for 100-percent signal span.
- **Low Air Consumption.** Enhanced pilot valve design and manufacturing technique allows the Type AV positioner maximum performance with minimum air consumption (Fig. 1-2).
- **Adjustable Speed Control without Additional Hardware.** Speed of actuator can be reduced to desired speed using the pilot valve stroke adjustment screws.

INSTRUCTION CONTENT

This instruction includes the following sections:

Introduction	Provides a description of this instruction; its sections and uses, along with a brief description of the Type AV1 and Type AV2 positioners. This section also provides reference documents (Table 1-2), product nomenclature (Table 1-2), specifications (Tables 1-3, 1-4 and 1-5), agency approvals (Table 1-6) and positioner accessories (Table 1-7). Table 1-8 lists retrofit mounting kits, Table 1-9 lists available speed control orifices, and Table 1-10 lists the available pressure gages. Table 1-11 lists pressure regulators, Table 1-12 lists supply air filters available from ABB and Table 1-13 lists the materials used in the positioner components.
Description and Operation	Describes the functional operation of the positioners.
Installation	Provides information about installing a Type AV positioner.
Calibration	Provides calibration and adjustment procedures.
Operating Procedures	Presents information and procedures for various applications.
Troubleshooting	Provides a table containing errors, causes and corrective action.
Maintenance	Includes preventive maintenance information and procedures.
Repair and Replacement	Procedures in this section give step-by-step instructions for removing and replacing components.
Support Services	Provides recommended spare and replacement parts lists. Illustrations of both positioners provide part numbers for all major components.
Appendix A	Provides calibration information about the four to 20-milliamp position transmitter and the potentiometric position transmitter.
Appendix B	Quick start section for control engineers that are knowledgeable about positioners and the overall process in which the positioner is to be used.
Appendix C	Details cam shaping information.
Appendix D	Covers the pneumatic position transmitter option.

HOW TO USE THIS INSTRUCTION

For safety reasons, read and completely understand this instruction before completing any tasks or procedures associated with installation, calibration, operation, maintenance or repair.

INTRODUCTION

The section arrangement of this instruction is sequential. After initial start-up and calibration, store this instruction in a safe place for future reference.

REFERENCE DOCUMENTS

Table 1-1. Reference Documents

Number	Title
ANSI/NFPA 70	National Electrical Code
CEC	Canadian Electrical Code
D-AAP-UP	Universal Pneumatic Rotary Actuator, Type UP (specification)
D-APE-AV1234	Characterizable Positioners, Type AV1, AV2, AV3 & AV4 (specification)
CSA c22.1	Process Control Equipment
I-E96-500	Site Planning and Preparation
I-P81-20	Universal Pneumatic Rotary Actuator, Type UP (instruction)
ANSI/ISA-7.0.01-1996	Quality Standards for Instrument Air
ISA S75.13-1989	Method of Evaluating the Performance of Positioners with Analog Input Signals and Pneumatic Output (Instrument Society of America)
P-P88-001	Product Application Guide, Installing a Type AV Positioner in a Hazardous Location

NOMENCLATURE

Table 1-2. Nomenclature

Position	1	2	3	4	5	6	7	8	9	Type	A	V	Characterizable Positioners		
	1														Characterizable Pneumatic Positioner
		2													Characterizable 4 to 20-mA Input Positioner (actuator moves to 0% or 100% upon loss of signal)
															Input Signal
				1											20.7 to 103.4 kPa (3.0 to 15.0 psig) (Type AV1)
				2											20.7 to 186.2 kPa (3.0 to 27.0 psig) (Type AV1)
				3											4 to 20 mA (standard intrinsically safe Type AV2)
				5											20.7 to 103.4 kPa (3.0 to 15.0 psig), high temperature applications (Type AV1) ¹
				6											20.7 to 186.2 kPa (3.0 to 27.0 psig), high temperature applications (Type AV1) ¹
				7											4 to 20 mA with explosionproof I/P converter (NEMA 7) (Type AV2) ²
															Stroke/Rotary Motion (cam selection)
					1										12.7 to 50.8 mm (0.5 to 2.0 in.) or 45° rotary motion
					2										25.4 to 101.6 mm (1.0 to 4.0 in.) or 90° rotary motion

REFERENCE DOCUMENTS

Table 1-2. Nomenclature (continued)

Position	1	2	3	4	5	6	7	8	9
Type	A	V	-	-	-	-	-	-	-
			Prev						
									Characterizable Positioners
									Manifold (includes filters)/Gage Block
					0				No manifold
					1				Manifold with equalizing valve, filters and gage ports (required for double acting actuators with manual override)
					2				Manifold with equalizing valve inoperable (includes filters and gage ports) ³
					3				Gage block (gage port only) ¹
									Position Transmitter
					0				None (must be 0 for Types AV15, AV16 and AV27)
					1				Potentiometric resistive output
					2				4 to 20-mA output
									Drive Shaft
					0				Standard with feedback arm for linear motion
					1				0.500-in. square end
					2				0.342-in. square end for older DeZurik actuators
					3				0.250 in. across flats (UP1 and UP2 after August, 1995)
					4				0.375 in. square for DeZurik PowerRac [®] actuators
					5				0.156 in. across flats for NAMUR rotary actuators
									Other Options
					0				Standard (no other options)
					N				NEMA 4X enclosure rating (when installed per drawing C258567)
					P				Performance Series — high pneumatic gain for large actuators

NOTES:

1. High temperature Type AV1 positioners are only available without manifolds or position transmitters; however, gage blocks are permitted.
2. Explosionproof Type AV2 positioners are not available with position transmitters or manifolds
3. No longer available as of October 2003..

SPECIFICATIONS

Table 1-3 provides performance specifications of the Type AV1 and Type AV2 positioners. Tables 1-4 and 1-5 provide performance specifications for the position transmitters.

Table 1-3. Type AV1/2 Positioner Specifications¹

Property	Characteristic/Value
Input range	
AV11 and AV15	20.7 to 103.4 kPa (3.0 to 15.0 psig)
AV12 and AV16	20.7 to 186.2 kPa (3.0 to 27.0 psig)
AV23 and AV27	4 to 20 mA
Input impedance (Type AV2 only)	
Nominal	215 Ω at 22°C (72°F)
Maximum	245 Ω at 60°C (140°F)

INTRODUCTION

Table 1-3. Type AV1/2 Positioner Specifications¹ (continued)

Property	Characteristic/Value
Standard stroke range (cam selection) AV__1____ AV__2____	12.7 to 50.8 mm (0.5 to 2.0 in.) linear, rotary input 45° 25.4 to 101.6 mm (1.0 to 4.0 in.) linear, rotary input 90°
Gain	2 adjustment levels by changing gain hinge spring. Refer to the flow gain curves as shown in Figures 1-3 and 1-4 for standard and high gain units.
Accuracy ² AV1 AV2	0.80% of span maximum 0.90% of span maximum
Resolution AV1 AV2	0.09% of span maximum 0.30% of span maximum
Hysteresis ² AV1 AV2	0.45% of span maximum 0.70% of span maximum
Repeatability ² AV1 AV2	0.12% of span maximum 0.50% of span maximum
Deadband ² AV1 AV2	0.12% of span maximum 0.30% of span maximum
Linearity ²	0.70% of span maximum
Supply pressure	172 to 1034 kPa (25 to 150 psig) NOTE: Minimum supply pressure should be 34.4 kPa (5.0 psig) above operating pressure required by actuator.
Supply pressure effect	0.05% per 6.9 kPa for ±69 kPa change (0.05% per 1.0 psi for ±10 psig change)
Capacity (maximum capacity exhausting to atmosphere)	Refer to Figure 1-1.
Air consumption	Refer to Figure 1-2.
Vibration effect ²	<2.0% error for: 5 to 15 Hz at peak-to-peak constant displacement of 4 mm (0.16 in.) 15 to 120 Hz at accelerations to 2 Gs
Pneumatic connections	¼-NPT on supply, signal and output connections ⅜-NPT on pressure gages
Materials of construction Enclosure Pilot valve	Aluminum and <0.5% magnesium 303 stainless steel
Enclosure classification Standard AV____N	NEMA 3R classification when vent hole is protected from rain using rain elbow (½-NPT street elbow, refer to Figure 3-1). NEMA 4X when installed per drawing C258567.

SPECIFICATIONS

Table 1-3. Type AV1/2 Positioner Specifications¹ (continued)

Property	Characteristic/Value
Weight	
AV1	1.84 kg (4.06 lbs)
AV2 (standard)	2.32 kg (5.11 lbs)
AV2 (explosionproof)	2.95 kg (6.51 lbs)
Temperature limits	
Operating	
AV11/2	-40°C to 82°C (-40°F to 180°F) ³
AV15/6	-20°C to 127°C (-4°F to 250°F) ³
AV2	-20°C to 82°C (-4°F to 180°F) ³
Storage	
AV11/2	-40°C to 93°C (-40°F to 200°F)
AV15/6	-20°C to 127°C (-4°F to 250°F)
AV2	-20°C to 82°C (-4°F to 180°F)
Humidity limits	
Operating	0% to 95% noncondensing
Storage	0% to 95% noncondensing

NOTES:

1. Performance testing performed on a ABB Type UP10 actuator.
2. Tested according to ISA-S75.13-1989
3. For operation below 4.4°C (40°F), dew point of the supply air must be 10°C (18°F) lower than the lowest expected operating temperature.

SPECIFICATIONS SUBJECT TO CHANGE WITHOUT NOTICE.

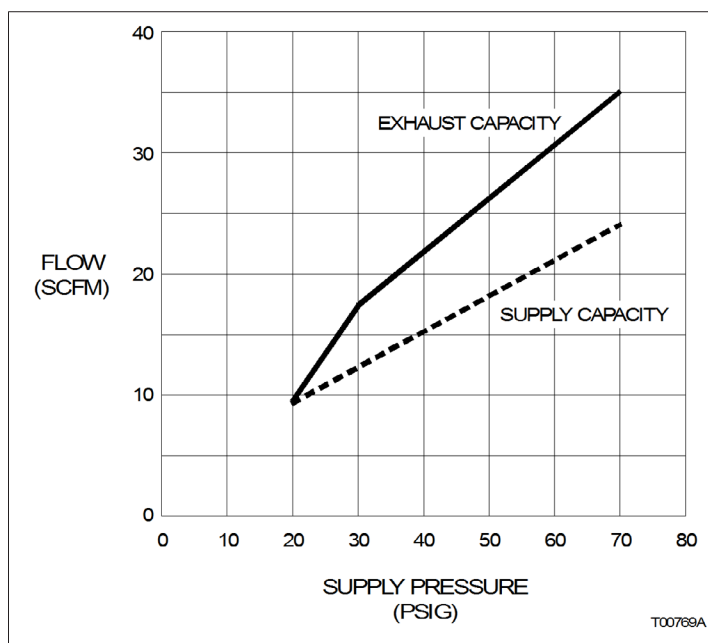

Figure 1-1. Capacity (Exhaust to Atmosphere)

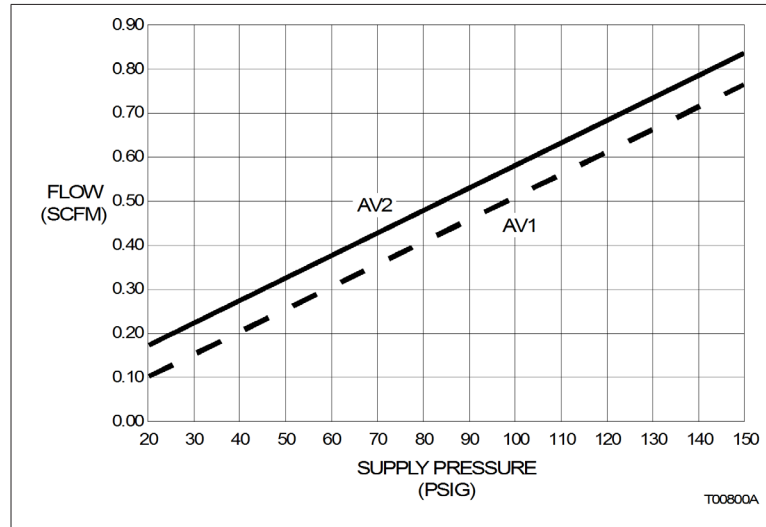

Figure 1-2. Air Consumption

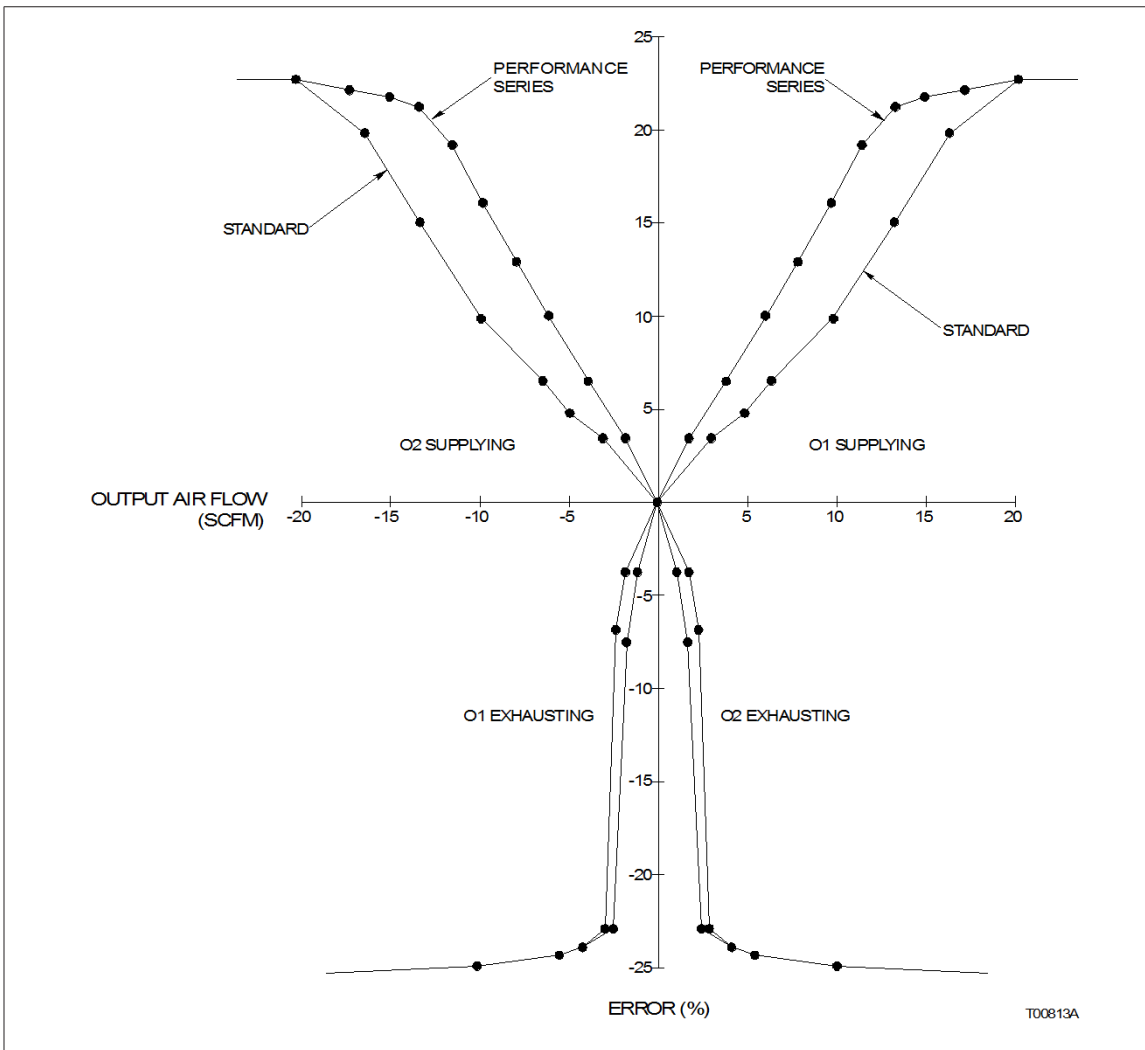

Figure 1-3. Output Air Flow vs. Error Signal — Standard and Performance Series

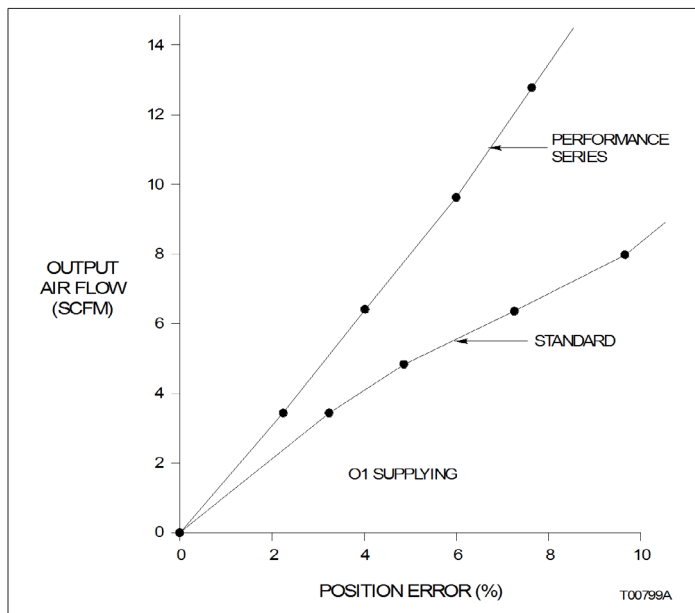

Figure 1-4. Expanded First Quadrant View of Figure 1-3

Table 1-4. Type AV___1___ Potentiometric Position Transmitter Specifications

Property	Characteristic/Value
Total resistance	2000 Ω, ±20%
Power rating	1 W up to 70°C (158°F), 0 W at or above 125°C (257°F)
Wiper rate of change	9.9 Ω nominal per degree of cam rotation
Temperature effect	0.05% (500 ppm) per °C (0.03% (278 ppm) per °F) maximum
Maximum voltage	35 VDC or 30 VAC across the potentiometer ends
Temperature limits	
Operating	-40°C to 82°C (-40°F to 180°F)
Storage	-40°C to 93°C (-40°F to 200°F)

SPECIFICATIONS SUBJECT TO CHANGE WITHOUT NOTICE.

Table 1-5. Type AV___2___ 4 to 20-mA Position Transmitter Specifications

Property	Characteristic/Value
Supply voltage	16 to 34 VDC
Output signal	4 to 20 mA
Output loading	500 Ω at 24 VDC, 1000 Ω at 34 VDC
Accuracy	<0.6% of span (maximum)
Hysteresis	<0.5% of span (maximum)
Ambient temperature effect	<0.063% per °C (<0.035% per °F)
EMI/RFI effect	<1.5% maximum at 10 V/m field strength, 20 to 450 MHz
Temperature limits	
Operating	-40°C to 82°C (-40°F to 180°F)
Storage	-40°C to 93°C (-40°F to 200°F)

SPECIFICATIONS SUBJECT TO CHANGE WITHOUT NOTICE.

INTRODUCTION

Table 1-6. Agency Approvals¹

Nomenclature	Approval/Certification ²	
AV1 and AV23	<p>Factory Mutual Research (FM):</p> <p>Approved as nonincendive for: Class I, Division 2, Groups A, B, C and D Class II, Division 2, Groups F and G Class III, Division 2</p> <p>Approved as intrinsically safe for: Class I, Division 1, Groups A, B, C and D Class II, Division 1, Groups E, F and G Class III, Division 1</p>	<p>Canadian Standards Association (CSA):</p> <p>Certified as: Class 1, Division 2, Groups A, B, C and D Class II, Division 2, Groups E, F and G Class III, Division 2</p> <p>Certified as intrinsically safe for: Class I, Division 1, Groups A, B, C and D Class II, Division 1, Groups E, F and G Class III, Division 1</p>
AV27__0__	<p>Factory Mutual Research (FM):</p> <p>Approved as explosionproof for: Classes I, II; Division 1, Groups B, C, D, E, F and G</p>	<p>Canadian Standards Association (CSA):</p> <p>Certified as explosionproof for: Classes I, II; Division 1, Groups B, C, D, E, F and G</p>
All	<p>This product complies with all applicable European Community product requirements, and specifically with those required to display the CE marking on the product nameplate.</p>	

NOTES:

- Hazardous locations approvals for use in flammable atmospheres are for ambient conditions of -25°C to 40°C (-13°F to 104°F), 86 to 106 kPa (12.5 to 15.7 psig) with a maximum oxygen concentration of 21%.
- For installing the positioner in a hazardous location, refer to **Product Application Guide, Installing a Type AV Positioner in a Hazardous Location**.

Table 1-7. Accessories¹

Accessory	Description
Mounting kits	Dependent on valve stem size (Figure 9-1, kit number 5327321__). For ABB retrofit kits, refer to Table 1-8.
Speed control orifices	Regulate time constant of positioner and final control device. Orifices are installed directly into positioner output ports (refer to Table 1-9). Speed adjustment can also be controlled by using the internal stroke adjustment screws (refer to PILOT VALVE STROKE ADJUSTMENT in Section 4).
Pressure gages	For reading signal, supply and output pressures (refer to Table 1-10).
Blank cam	Used to characterize the positioner if the standard cams (square, linear, square root) will not produce the desired relationship. Blank cam must be profiled (part number 5400277_1).
Supply air regulator	Refer to Table 1-11.
Pneumatic position transmitter	Refer to Appendix D (Type AV1__0__ positioner only).
Air filters	ABB recommends installing an air filter in the supply air line to prevent particles from entering the positioner that can lead to malfunctions. Refer to Table 1-12 for filter part numbers.
Manifold Filters	For addition or replacement of secondary air filters on manifold-equipped positioners. Kit number 258487_1.
Bypass valve assembly	Part number 5326945_1. Refer to Table 9-24 and Figure 9-2.

NOTE:

- For recommended spare parts and additional spare parts, refer to Section 9.

SPECIFICATIONS

Table 1-8. Rotary Actuator Retrofit Mounting Kits

Kit Number	Drive Nomenclature	Retrofit Mounting Kit
5400309_1	UP1, UP2	Type AP positioner to Type AV positioner
258493_1	UP3, UP4	
258494_1	UP5, UP6	
258527_1	AC0404	
258528_1	AC0608	
258529_1	AC0816	
258530_2	AC1016	ABB part number pilot valve positioner to Type AV positioner
258527_1	AC0404	
258528_1	AC0608	
258529_1	AC0816	
258530_1	AC1016	

Table 1-9. Speed Control Orifices¹

Part Number	Size	
	mm	in.
5327327_1	1.02	0.04
5327327_2	Blank (drill to suit)	Blank (drill to suit)

NOTE:

1. Speed control can also be obtained by internal positioner adjustment. Refer to **PILOT VALVE STROKE ADJUSTMENT** in Section 4.

Table 1-10. Pressure Gages

Part Number	Legend	Range	
		kPa	psig
5326605_4	Instrument	0 to 200	0 to 30
5326605_5	Supply ¹	0 to 1,000	0 to 160
5326605_6	Output	0 to 1,000	0 to 160

NOTE:

1. The optional manifold provides gage ports, one for instrument (internal input signal), and two output gages. A supply gage can be installed in the supply line (piping by customer).

Table 1-11. Supply Air Regulators with Gages

Part Number	Max. Outlet Pressure (psig)	Max. Inlet Pressure (psig)	Inlet/Outlet Connections
1951029_5	125	250	¼ NPT

Table 1-12. Supply Air Filters¹

Part Number	Max. Inlet Pressure (psig)	Max. Temperature		Inlet/Outlet Connection Size
		°C	°F	
5328563_2	250	121.0	125.0	¼ NPT

NOTE:

1. In-line coalescing filter for removal of solid and liquid contaminants in compressed air. Filter comes with universal mounting bracket and grade 6 filter that is 99.97% efficient at 0.3 micron. Part number 5328563_2 has a zinc bowl.

Table 1-13. Component Material List

Component	Material
Housing	Aluminum
Cover	Aluminum
Inserts	Lamond (thermoplastic elastomer)
Window	Lexan [®] (polycarbonate)
Screws	Stainless steel
Range spring	302 stainless steel
Pilot valve (stem and body)	303 stainless steel
Gain hinge spring	302 stainless steel
Cam	302 stainless steel
Cam shaft	303 stainless steel
Bearings	Bronze
Cam follower arm	Aluminum
Bearing	Stainless steel
Shaft	303 stainless steel
Spring arm	Aluminum
Zero adjustment nut	Aluminum
Indicator	Valox [®] — unreinforced (polybutylene terphthalate)
Tubing	Silicone
Drive arm	Aluminum
Teflon [®] washers	Teflon
Fasteners	Steel/stainless steel
Signal connector	Nylon
Diaphragms	
All except Types AV15 and AV16	Buna-N with Dacron fabric
Types AV15 and AV16	Fluorosilicone with Dacron fabric
Diaphragm plastic parts	Rynite [®] (FR-530) polyethylene terphthalate
Gage block (optional)	Aluminum
O-rings	
All except Types AV15 and AV16	Buna-N
Types AV15 and AV16	Viton [®]
Manifold (optional)	Aluminum
Adhesive	Epoxy
Handle	Rynite
Plate	Aluminum
Plug	Stainless steel
Valve	Aluminum
Valve handle	Rynite

Table 1-13. Component Material List

Component	Material
Position transmitter (optional) (AV____1/2__) Gears Gear hub	Delrin [®] (coolymer acetal) Brass
Additional Type AV2 components Regulator ¹ Regulator bracket ¹ Tubing I/P converter	Polysulfone ¹ 304 stainless steel ¹ Nylon Copper Copper clad glass laminate Monel [®] 405 Nickel-iron Noryl [®] (phenylene ether/phenylene) Polyethylene Polyester magnet wire Rare earth magnet Zinc

NOTE:

1. Regulator not applicable for AV2s after July, 2001.

SECTION 2 - DESCRIPTION AND OPERATION

INTRODUCTION

This section describes and explains the functional and physical operation of Type AV1 and AV2 positioners. Figure 2-1 diagrams the operating principles of the positioners. Figure 2-2 shows the placement of a positioner in a typical control system.

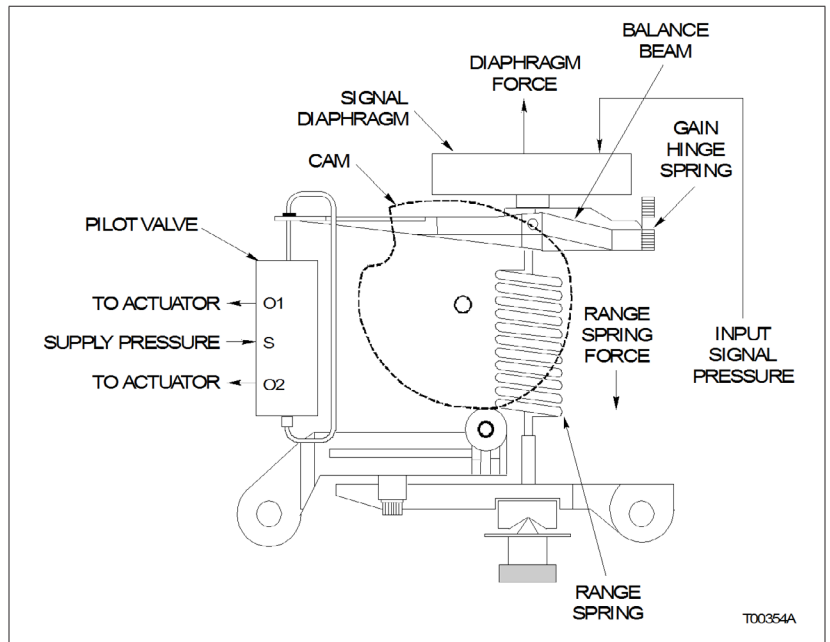

Figure 2-1. Operation Diagram

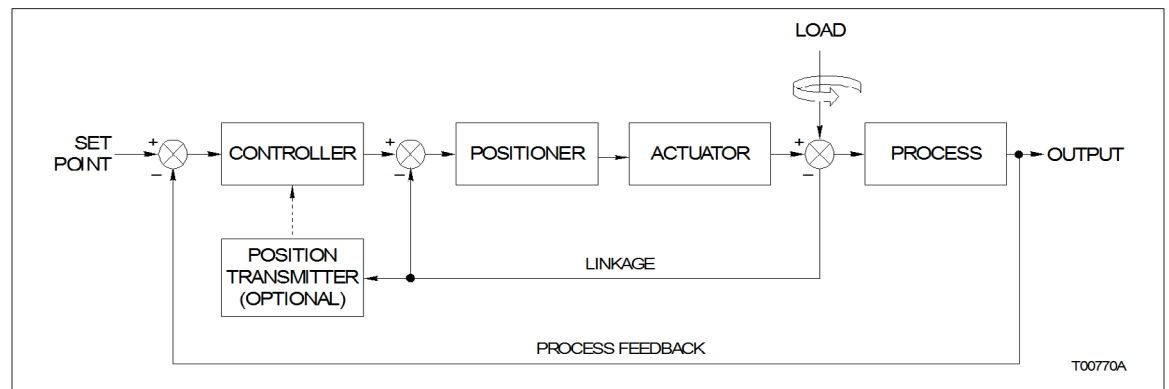

Figure 2-2. Block Diagram

FUNCTIONAL OPERATION

Type AV positioners operate by balancing opposing forces. Figure 2-1 shows a diagram of the Type AV positioner. A balance beam, hinged at one end and connected to the pilot valve at the other, is acted upon by two forces:

- Upward force of the signal diaphragm assembly.
- Downward force from the range spring.

The input signal pressure determines the diaphragm force. The Type AV1 positioner uses an external input pressure (either 20.7 to 103.4 kilopascals (3.0 to 15.0 pounds per square inch gage) or 20.7 to 186.2 kilopascals (3.0 to 27.0 pounds per square inch gage)). The Type AV2 positioner uses a current to pneumatic converter to generate the input signal pressure.

The range spring force is a function of the shape and position of the cam. The cam is coupled to the cam shaft that is connected through linkage (or coupling) to the actuator. Therefore, range spring tension is a function of the actuator position.

A change in input signal changes the force exerted by the signal diaphragm, moving the balance beam, in turn moving the pilot valve. The pilot valve supplies and/or exhausts air to the actuator that ultimately changes its position. The change in actuator position is fed back to the positioning cam. The positioning cam moves, changing the tension of the range spring until a balanced condition once again exists.

The positioner is normally located in a control loop (Fig. 2-2) between the controller and the actuator.

Actuator position is fed back to the positioner for comparison with the position commanded by the input control signal (direct signal pressure or a current value). For linear motion actuators, the feedback mechanism consists of:

- A drive rod that follows the motion of the actuator.
- An adjustable-length, swivel-ended connecting link that transmits the motion of the drive rod to an adjustable drive arm on the positioner.
- A camshaft and cam that are rotated through an angle by the drive arm. A function of the cam is to permit characterization of actuator position versus input signal.

SECTION 3 - INSTALLATION

INTRODUCTION

Several applications are possible using a Type AV positioner. The steps for installing a Type AV positioner are in sequence in this section. After installation is complete, refer to [Section 4](#) for calibration information.

- Unpack and inspect the equipment.
- Mount the positioner.
- Connect tubing to the positioner.
- Connect wiring to the positioner.

NOTES:

1. For application in a hazardous location, refer to ABB *Product Application Guide, Installing a Type AV Positioner in a Hazardous Location*.

2. [Appendix B](#) provides a quick start guide for the Type AV positioner. It is intended for control engineers having extensive experience in the use and application of pneumatic positioners. The quick start guide highlights the major points of installation and calibration. Detailed installation and calibration information is contained in this section and in [Section 4](#).

WARNING

Select an installation method that provides a fail safe mode upon loss of controller signal. Certain installation methods do not stroke the equipment to a fail safe condition upon loss of controller signal. Failure to select a fail safe installation method could cause injury to personnel and damage to equipment.

UNPACKING AND INSPECTION

1. Check for obvious damage to the shipping carton.
2. Open the carton and remove all loose packing.
3. Carefully remove the positioner from the carton and inspect for any physical damage that may have occurred during shipping.
4. Remove the two cover screws and the positioner cover and examine the interior for any loose components such as nuts, screws, springs, etc. Check the data on the nameplate to be certain the positioner type ordered for the application was received.

INSTALLATION

5. If the positioner is suitable for the application and appears undamaged, install the cover and proceed with the installation instructions.
6. If storing the positioner prior to installation, leave it in the original carton, if possible. Store in an area free from corrosive vapors and extremes in temperature and humidity.
7. Do not store the positioner in an area that would take it out of the specifications listed in Tables 1-3, 1-4 and 1-5.

ENCLOSURE CLASSIFICATION

The standard enclosure for the Type AV1 and Type AV2 positioners conform to NEMA 3R when a ½-14 NPT street elbow (Fig. 3-1) is installed into the vent hole on the housing. The elbow prevents water or other liquid from entering the enclosure. The position of the elbow is related to the mounting plane of the positioner in its service location. The elbow must be positioned to face downward. The NEMA 3R version meets the extended corrosion resistance requirements of NEMA 250.

A NEMA 4X version is available as an option (Type AV_____N positioners). To maintain the NEMA 4X classification, the positioner shall be installed per drawing C258567 and suitable piping shall be attached to the vent opening and vented in a manner to preclude the entrance of water under pressure, as from a hose. Additionally, the conduit connections shall be suitable for a NEMA 4X rating.

MOUNTING CONSIDERATIONS

Choose a location for the positioner based on the following factors:

- Access to the internal positioner adjustments — the mounting location should provide enough room to remove the cover in order to perform calibration and repair and replacement procedures inside the positioner. Refer to Figure 3-1 for positioner dimensions. Figure 3-2 shows the electrical connections, Figure 3-3 shows the dimensions of the drive arm connections and Figure 3-4 shows the drive shaft variations.
- Allow room for linkage to the actuator — the mounting position should be such that a practical linkage arrangement can be made between the positioner and the actuator for full range travel.

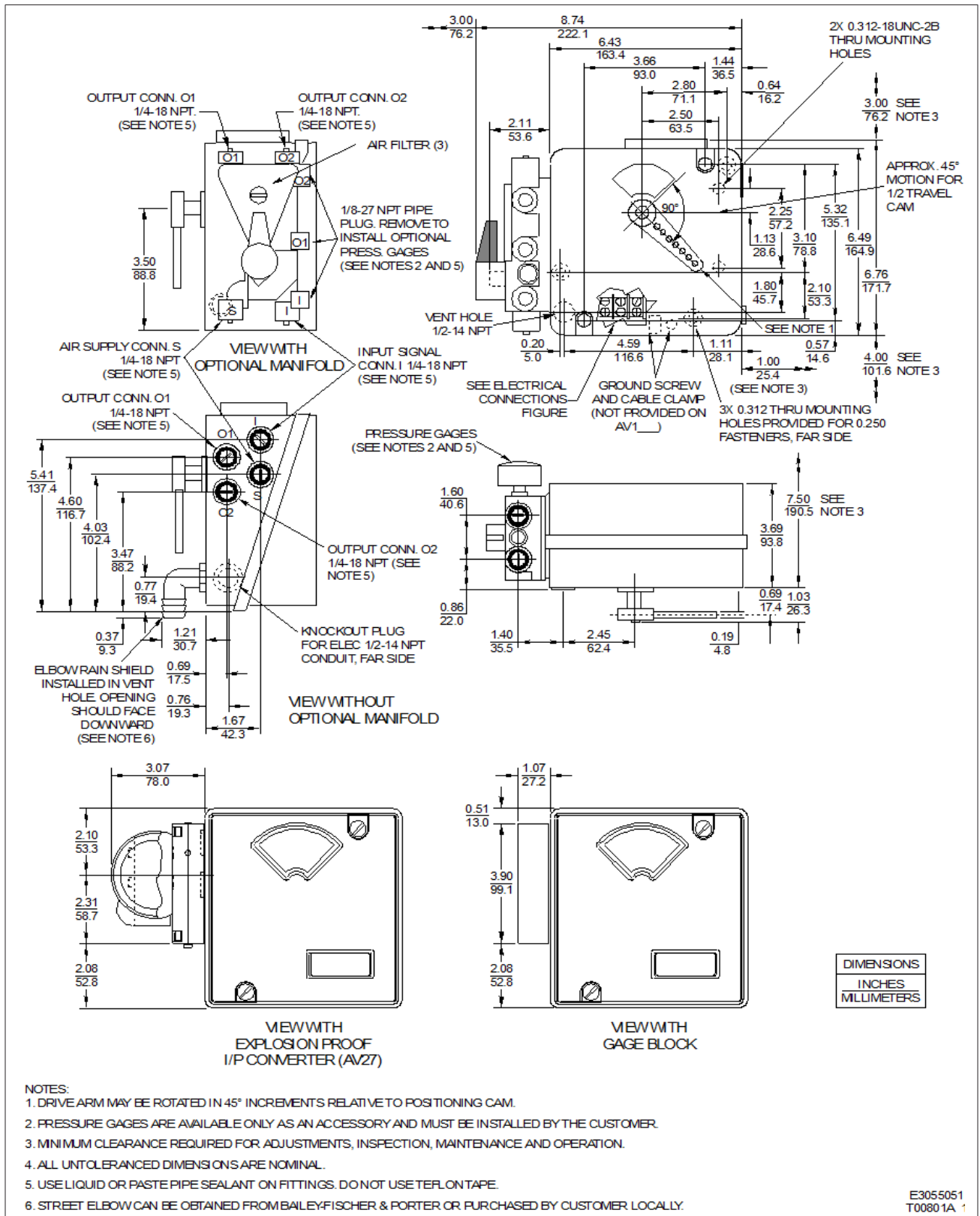

Figure 3-1. External and Mounting Dimensions

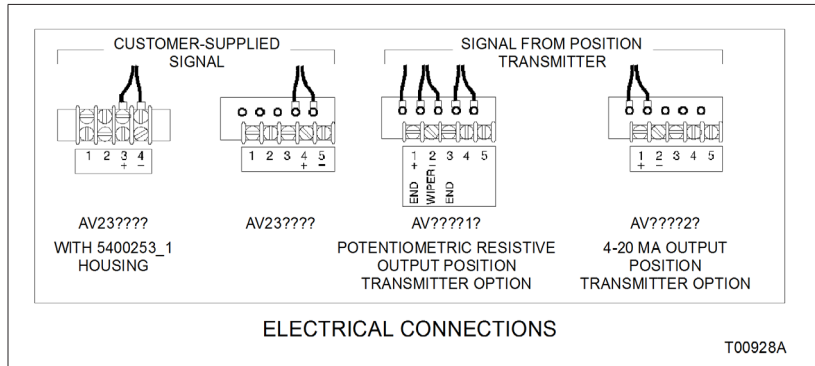

Figure 3-2. Electrical Connections

NOTE: For Type AV27, the 4-20 mA input signal wires shall be connected through an explosion-proof conduit entrance directly to the I/P converter.

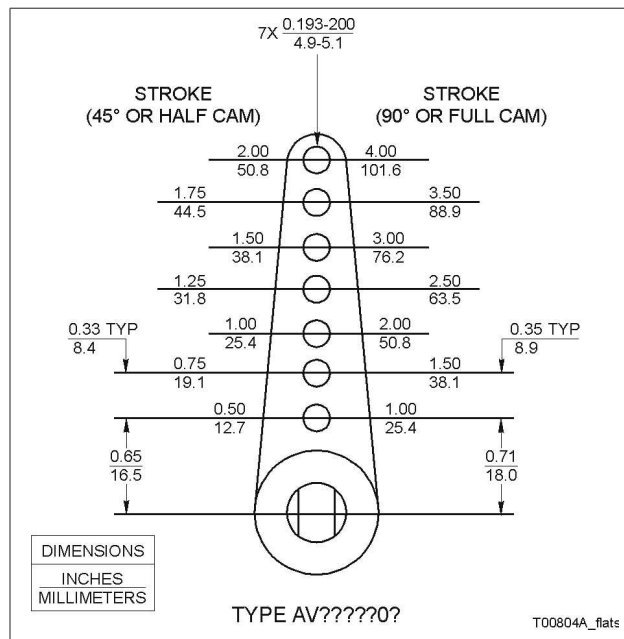

Figure 3-3. Drive Arm Connections

MOUNTING TYPE AV POSITIONERS

The Type AV positioner can be used with double acting or single acting actuators. Mounting and external dimensions are shown in Figure 3-1. Figure 3-5 shows a typical mounting arrangement using a ABB mounting kit. Refer to Figure 9-23 for an exploded view and complete parts list of

the kit. If using the positioner with a rotary actuator, the positioner can be directly connected to the actuator, as shown in Figure 3-6.

NOTE: If the actuator is equipped with a Type AV positioner as ordered, verify that all the connections are secure and make any adjustments as required.

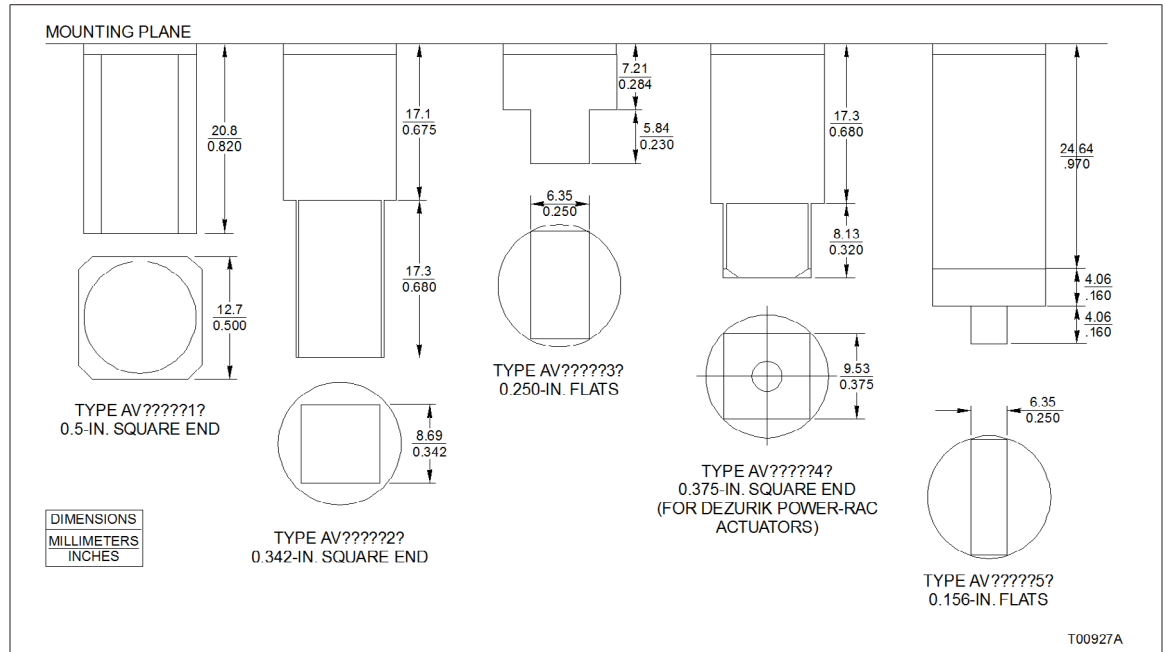

Figure 3-4. Drive Shaft Variations

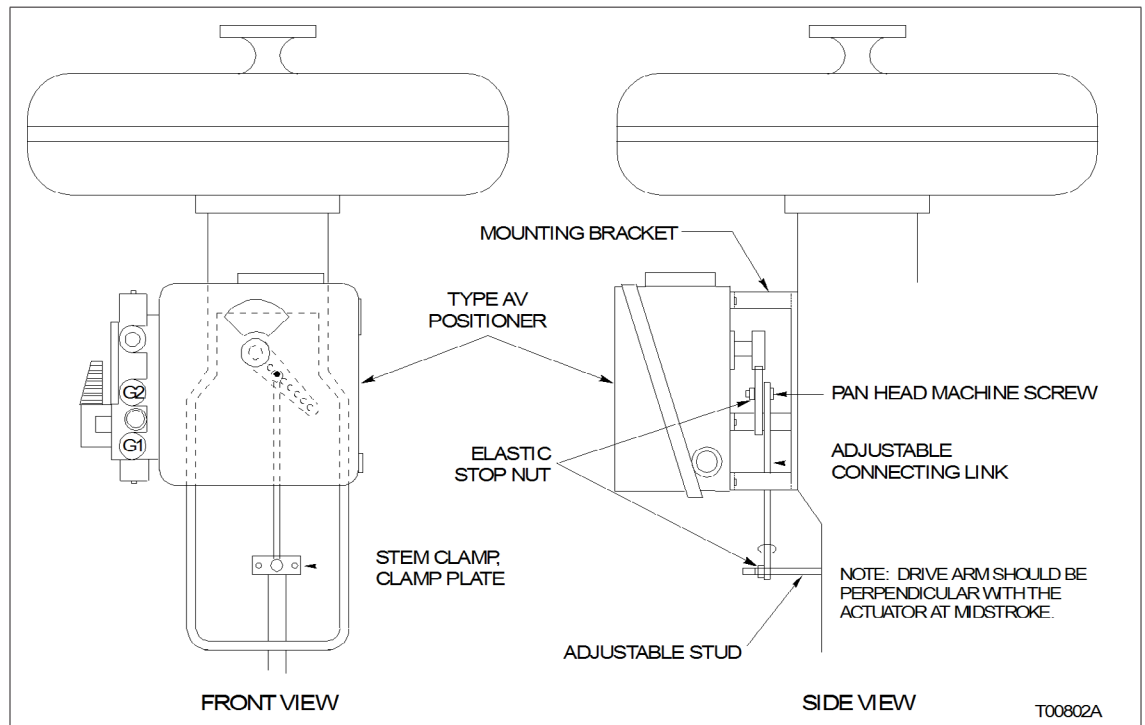

Figure 3-5. Mounting Using Linkage (Typical)

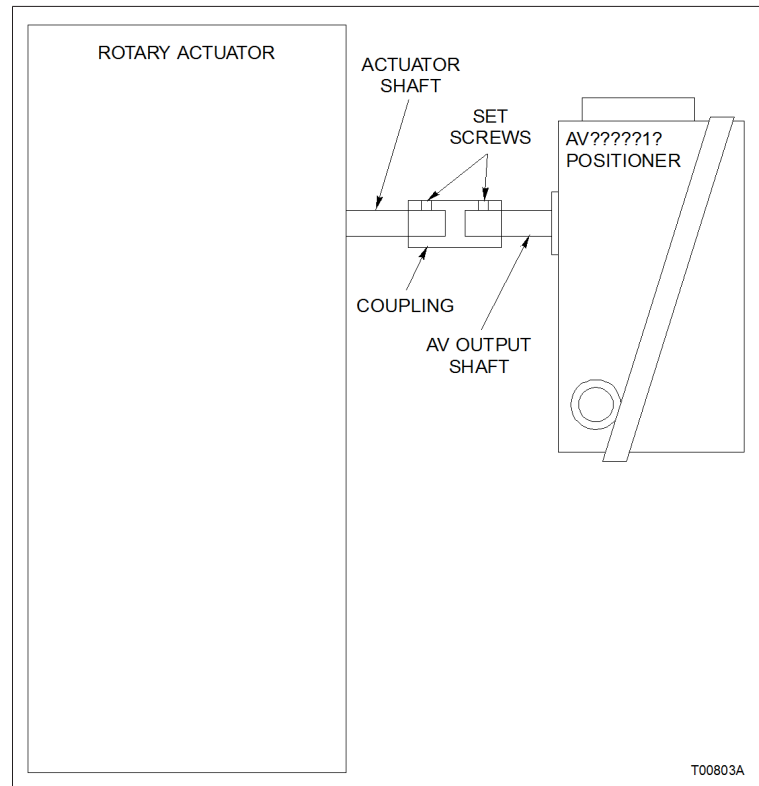

Figure 3-6. Mounting Using Direct Coupling (Typical)

Due to the wide range of applications that the Type AV positioner is suited for, we can only provide general information about mounting. Use the following procedure to mount the positioner.

WARNING

Before mounting or installing positioner, check nameplate data to make certain positioner is suitable for application desired. DO NOT AT ANY TIME EXCEED THE RATINGS LISTED ON THE NAMEPLATE.

1. Set the actuator at the zero position. Connect the adjustable linkage to the drive arm. The drive arm holes correspond to stroke length of the actuator. Refer to Figure 3-3 for the stroke length for each drive arm hole.
2. Install the cam (black, direct acting; or red, reverse acting) that will provide the required direction of rotation.

A direct acting (black) positioning cam with segments A, B and C (Fig. 3-7) and a reverse acting cam are furnished with each positioner. The **reverse acting** cam has **red** radial lines and arcs and is stored on the inside of the positioner cover. Cam A is for a square root function, cam B is for linear motion and cam C is for a

square function (Table 3-1). Cam B is in place when the positioner is shipped from the factory. The cams may be shaped to conform to special applications. Refer to Appendix C for information about cam shaping.

NOTE: If the application is reverse acting, the reverse acting cam (red radial lines) must be installed and the connections to ports 01 and 02 must be reversed.

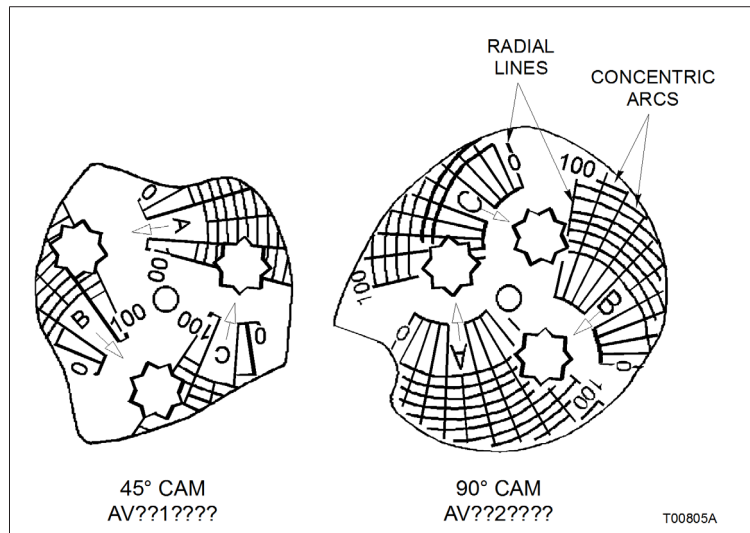

Figure 3-7. Cam

Table 3-1. Cam Characteristics

Positioning Cam Any Stroke	Piston or Valve Position (P) vs Control Signal (I)	Figure Number
A	Square root ($I = \sqrt{P}$)	C-1
B	Linear ($I = P$)	C-2
C	Square ($I = P^2$)	C-3

The cam, camshaft and drive arm rotate as an assembly. Cam motion is 90 degrees (Type AV__2__) or 45 degrees (Type AV__1__) depending on the positioner type specified by nomenclature (Figure 3-7).

Each cam shape (A, B or C) has its own eight-point center hole for mounting on the camshaft (Fig. 3-7). Place the cam in one of the eight 45-degree positions so that the midpoint of the cam corresponds to the mid stroke of the actuator. The drive arm should be perpendicular to the motion of the actuator with the actuator at mid stroke.

3. Adjust the connecting linkage so that the zero radial line on the cam intersects the center of the cam roller when the actuator is at its zero position (Fig. 3-8).

4. Lock all linkage components in place.

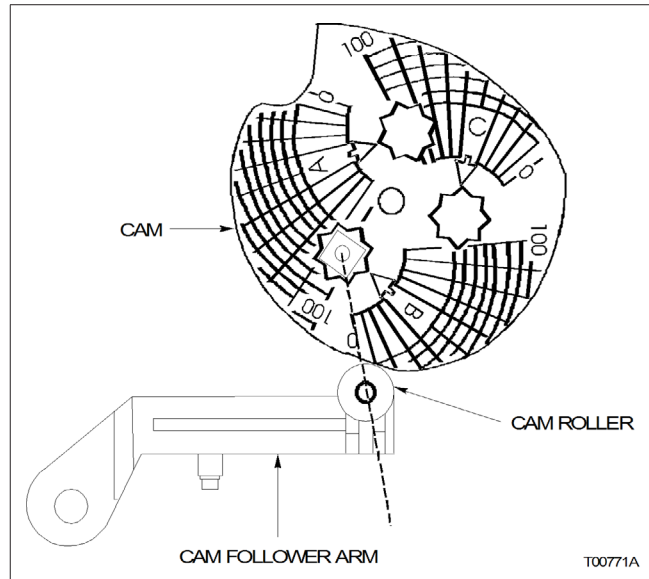

Figure 3-8. Cam Roller Alignment

TUBING CONNECTIONS

Type AV positioners are available with (Type AV__1__ and AV__2__) or without (AV__0__) manifolds. The following outlines supply air information and describes the piping connections.

Air Supply Pressure

CAUTION

Do not exceed the maximum supply pressure of 1034 kilopascals (150 pounds per square inch gage). Exceeding this pressure could cause equipment damage.

The air supply pressure range is 172 to 1034 kilopascals (25 to 150 pounds per square inch gage).

NOTE: The minimum supply pressure should be 34.4 kilopascals (5 pounds per square inch gage) above the operating pressure required by the actuator.

Air Supply Filtering

An external filter is recommended for Type AV positioners for primary filtration of the supply air. ABB provides supply air filters as accessories. Refer to Table 1-12 for part numbers.

NOTE: Primary air supply filters are recommended for positioners **with** a manifold (AV__1/2__), **without** a manifold (AV__0__) or with a gage block (AV__3__).

Positioners equipped with manifolds have three secondary filters as part of the unit. If the filters become clogged, they can be cleaned (by removing and reverse flushing with air or liquid) or replaced (refer to Table 1-7 for kit number). Refer to Section 7 for manifold filter replacement procedures.

Air Supply Quality (Recommended)

For long-term, trouble free operation, it is recommended that the supply air be of instrument quality and conform to the ANSI/ISA-7.0.01-1996 standard that includes the following:

- The pressure dew point as measured at the dryer outlet shall be at least 10°C (18°F) below the minimum temperature to which any part of the instrument air system is exposed. The pressure dew point shall not exceed 4°C (39°F) at line pressure.
- The oil content should be as close to zero as possible and, under no circumstances, shall it exceed one (1) ppm w/w or v/v.
- Instrument air should be free of corrosive contaminants and hazardous gases, which could be drawn into the instrument air supply.

In addition, the particle size in the supply line should not be greater than 3.0 microns.

Tubing Connections

1. Connect the required air supply to connection S (Fig. 3-9).

NOTE: Use liquid or paste pipe sealant to seal the connection. Maximum torque for ¼-NPT fittings is 13.6 Nm (10 ft-lbs).

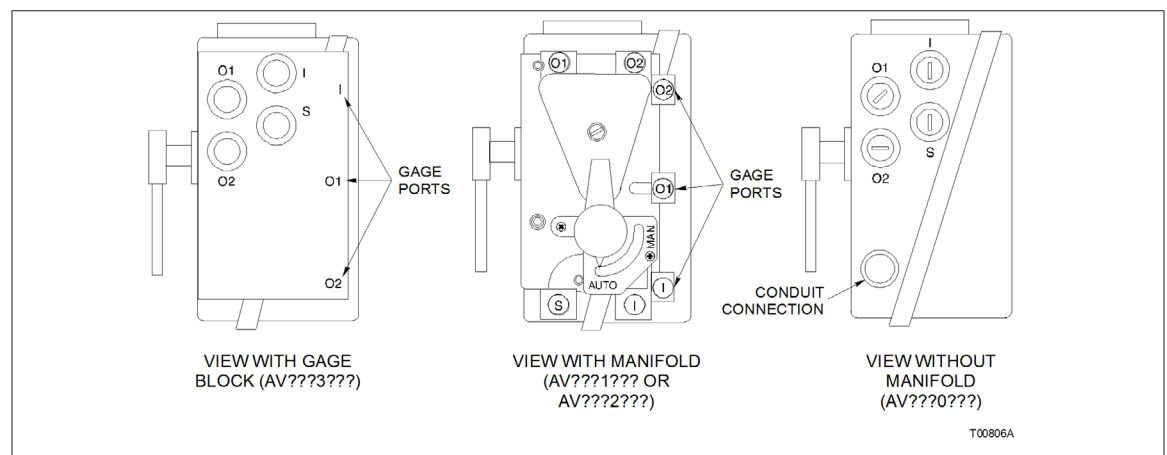

Figure 3-9. Port Locations

2. Based on the positioner type, perform one of the following steps (Fig. 3-9):

AV11 or AV15: Connect 20.7 to 103.4-kPa (3.0 to 15.0-psig) instrument signal to connection I.

AV12 or AV16: Connect 20.7 to 186.2-kPa (3.0 to 27.0-psig) instrument signal to connection I.

AV2: Connection I is not used and should be plugged. If it is not plugged, do so at this time.

3. Connect the output ports 01 and 02 as required to provide the desired direction of rotation. Figures 3-10, 3-11, 3-12 and 3-13 show single acting tubing examples, and Figure 3-14 shows a double acting tubing example. Air pressure to the 01 port increases from zero toward full supply as the control signal (error) increases. Air pressure to the 02 port decreases from full supply toward zero as the control signal increases.

NOTE: The tubing arrangements shown in Figures 3-10, 3-11, 3-12, 3-13 and 3-14 are typical examples and may not reflect the arrangement required for the application.

4. $\frac{1}{8}$ -NPT permanent instrument gages can be installed into the gage ports for calibration requirements.

WIRING TYPE AV2 POSITIONER

Use the following procedure to wire the Type AV2 positioner:

1. Connect the four to 20-mA position demand signal wires to terminals TB1-4 (+) and TB1-5 (-) of the terminal block (Figs. 3-2 and 3-15). For Type AV27 positioners, unscrew the I/P cover and make the four to 20-mA connections to the positive (+) and negative (-) terminals. If installing a Type AV2___0__ positioner, go to Step 4.

NOTE: If using a twisted shielded pair for signal wiring, ground one end of the shielded pair at the source. Trim the other end of the pair, located inside the enclosure, so that bare wires are not exposed.

2. If equipped with an optional 4 to 20-mA position transmitter (AV2___2__), connect a 24-VDC power supply in series with the required output load (Table 1-7) to terminals TB1-1 (+) and TB1-2 (-).
3. If equipped with an optional potentiometric position transmitter (Type AV2___1__), connect a power supply (maximum 35 VDC or 30 VAC) across TB1-1 and TB1-3. Use the signal across TB1-1 and TB1-2 or TB1-2 and TB1-3 for position transmitter feedback.

Refer to [Appendix A](#) for detailed information about position transmitters.

NOTE: Route the wiring inside the positioner so it does not become entangled with moving parts. A cable clamp (Figs. 3-1 and 4-1) is provided inside the positioner so entanglement can be avoided.

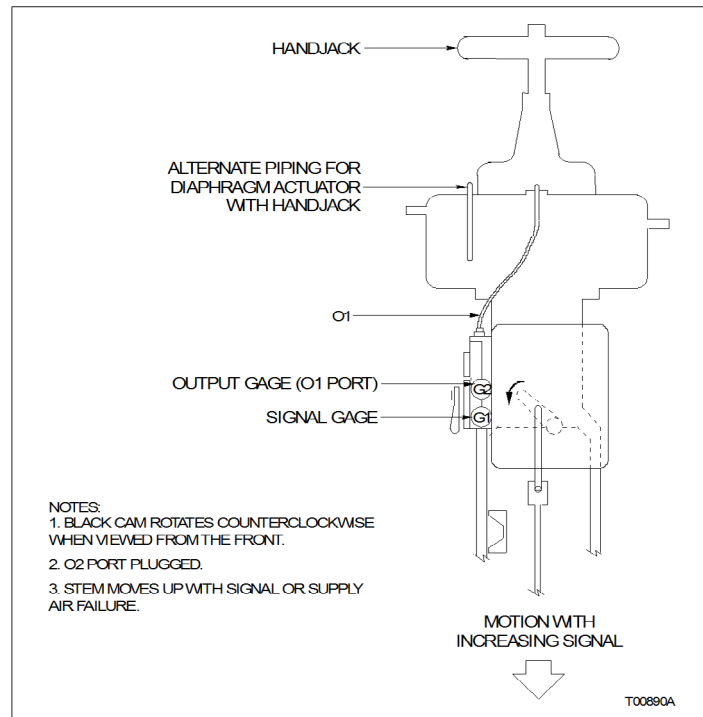

Figure 3-10. Direct Acting, Top Loaded, Single Acting Tubing Example

4. Grounding positioners should be done in accordance with local electrical codes (in U.S., National Electrical Code, ANSI/NFPA 70. In Canada, Canadian Electrical Code, CSA c22.1). A grounding screw is provided inside the enclosure for grounding, denoted by .

NOTES:

1. The grounding screw located inside the enclosure is a safety ground and should not be used to ground the shielded pair.
2. The positioner must be grounded to avoid ground loop conditions.

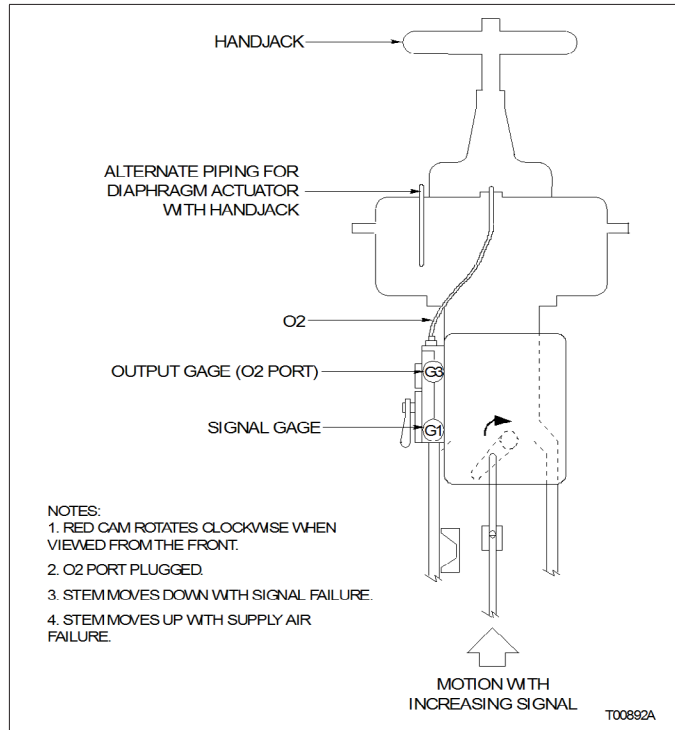

Figure 3-11. Reverse Acting, Top Loaded, Single Acting Tubing Example

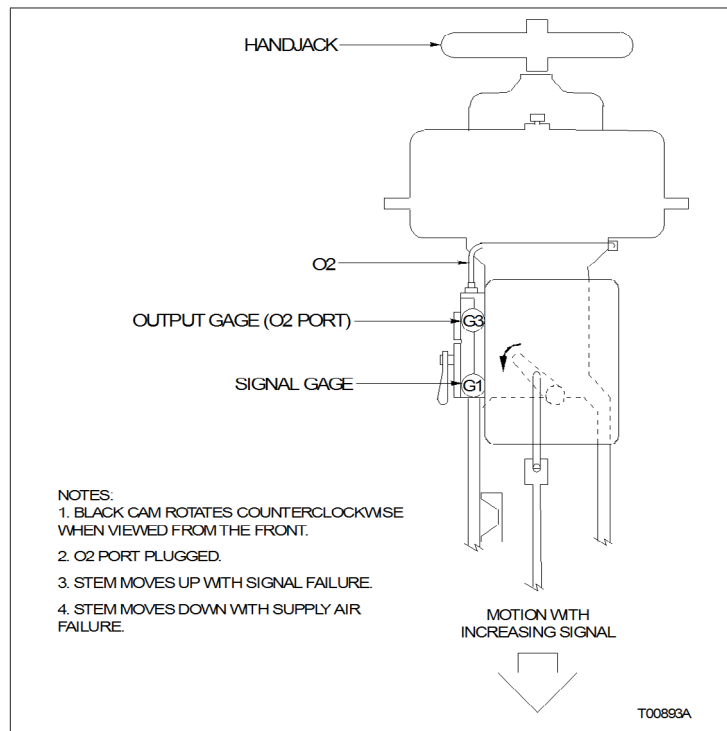

Figure 3-12. Direct Acting, Bottom Loaded, Single Acting Tubing Example

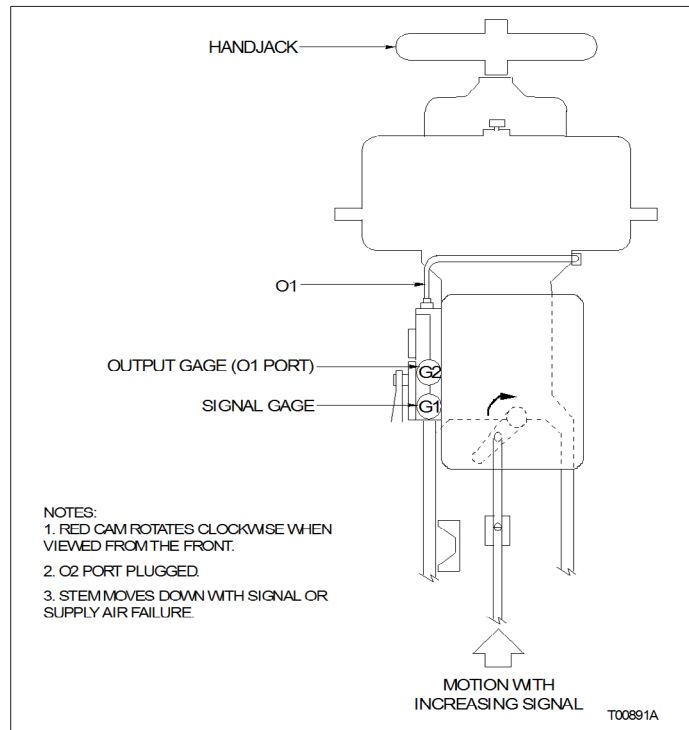

Figure 3-13. Reverse Acting, Bottom Loaded, Single Acting Tubing Example

WIRING TYPE AV1 POSITIONER

This section applies to the following positioners:

- Type AV1__1__.
- Type AV1__2__.

NOTES:

1. If this is a Type AV1__0__ positioner, no electrical wiring is required.
 2. If using a twisted shielded pair for signal wiring, ground one end of the shielded pair at the source. Trim the other end of the pair, located inside the enclosure, so that bare wires are not exposed.
1. If equipped with an optional 4 to 20-mA position transmitter (Type AV1__2__), connect a 24-VDC power supply in series with the required output load (Table 1-5) to terminals TB1-1 (+) and TB1-2 (-) (Figs. 3-2 and 3-15). Refer to Appendix A for detailed information about position transmitters.
 2. If equipped with an optional potentiometric position transmitter (Type AV1__1__), connect a power supply (maximum 35 VDC or 30 VAC) across TB1-1 and TB1-3. Use the signal across TB1-1 and TB1-2 or TB1-2 and TB1-3 for position transmitter feedback.

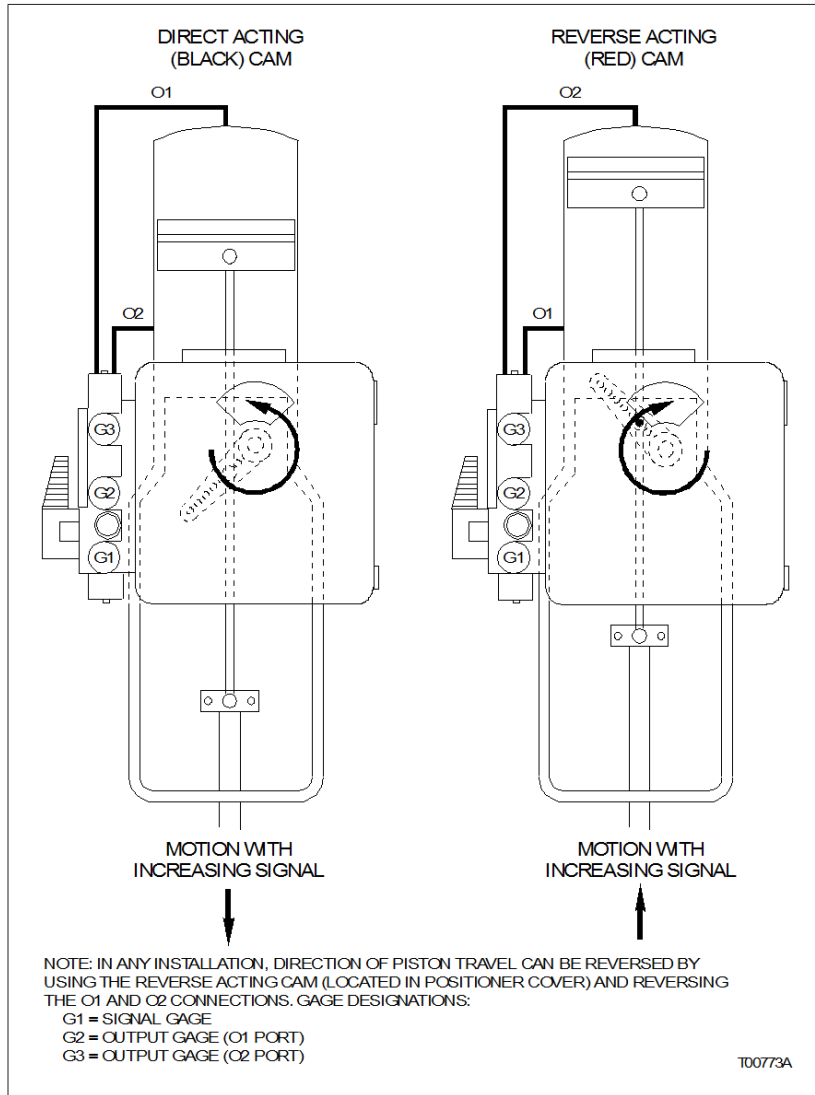

Figure 3-14. Double Acting Tubing Example

NOMENCLATURE	TB1 CONNECTIONS				
	1	2	3	4	5
AV23?????				+	-
AV33?????				+	-
AV44?????	+	-	+24	RAISE	LOWER
AV????1??					
AV????2??	+	-			

T00807A

Figure 3-15. Wiring Connections

Refer to **Appendix A** for detailed information about position transmitters.

NOTE: Route the wiring inside the positioner so it does not become entangled with moving parts. A cable clamp (Fig. 3-1 or 4-1) is provided inside the positioner so entanglement can be avoided.

3. Grounding positioners should be done in accordance with local electrical codes (in U.S, National Electrical Code, ANSI/NFPA 70. In Canada, Canadian Electrical Code, CSA c22.1). A grounding screw is provided inside the enclosure for grounding, denoted by .

NOTES:

1. The grounding screw located inside the enclosure is a safety ground and should not be used to ground the shielded pair.
2. The positioner must be grounded to avoid ground loop conditions.

RADIO FREQUENCY INTERFERENCE

Most electronic equipment is influenced by radio frequency interference (RFI). Caution should be exercised with regard to the use of portable communications equipment in the area.

ABB recommends posting appropriate signs in the plant. Refer to the ***Site Planning and Preparation*** instruction for additional information on RFI.

WIRING REQUIREMENTS

Under ideal conditions, the use of conduit and shielded wire may not be required. However, to avoid noise problems, it is recommended that wiring be enclosed in conduit. Just prior to entering the housing, rigid conduit should be terminated and a short length of flexible conduit should be installed to reduce any stress.

SECTION 4 - CALIBRATION

INTRODUCTION

This section contains the following information:

- Calibration.
- Gain adjustment.
- Speed control.
- Troubleshooting calibration.

NOTES:

1. All procedures in this section assume direct acting operation.
2. The troubleshooting calibration procedure in this section is not required for normal operation. The procedure is used only when operating difficulties occur. The corrective action column of Table 6-1 indicates when to use the troubleshooting calibration.
3. Calibration can also involve cam shaping to achieve the required control characteristics. Refer to Appendix C for detailed information about the cam.

CALIBRATION

Tools required: $\frac{3}{32}$ -inch Allen wrench.

Mechanical linkage is performed during installation (Section 3) that normally consists of adjusting the connection between the positioner and actuator so that the mechanical zero on the positioning cam corresponds to the mechanical zero of the actuator. The calibration procedure detailed here involves fine adjustments to the zero and span such that the input signal will cause the desired travel.

Calibration consists of applying an input signal pressure to the positioner to set the zero and span. These adjustments are made with the supply air applied to the positioner.

Type AV positioners have position transmitter options that are available for feedback purposes. Refer to Appendix A for more information about the position transmitter options.

Zero Adjustment

The positioner zero adjustment sets the tension on the range spring and adjusts the input signal level that causes the actuator to move off of the minimum travel stop. The zero percent radial line of the cam should align with the center of the cam roller (Fig. 4-2).

Use the following steps to adjust the zero:

1. Depending on the nomenclature type, apply one of the following input signals:

Type AV1 20.7 kPa (3.0 psig) input signal pressure. The actuator should move to its fully closed position.

Type AV2 4.0 mA input signal. The actuator should move to its fully closed position.

2. To adjust the zero, loosen the zero adjustment set screw (Fig. 4-1) with the $\frac{3}{32}$ -inch Allen wrench.

3. Turn the zero adjustment nut (clockwise moves the actuator toward minimum span) until the zero radial line on the cam intersects with the center of the cam roller (Fig. 4-2).

NOTE: This adjustment may be biased; i.e., turning the zero adjustment nut slightly clockwise to make sure a valve or damper is firmly seated at the minimum input signal.

4. Tighten the zero adjustment set screw.

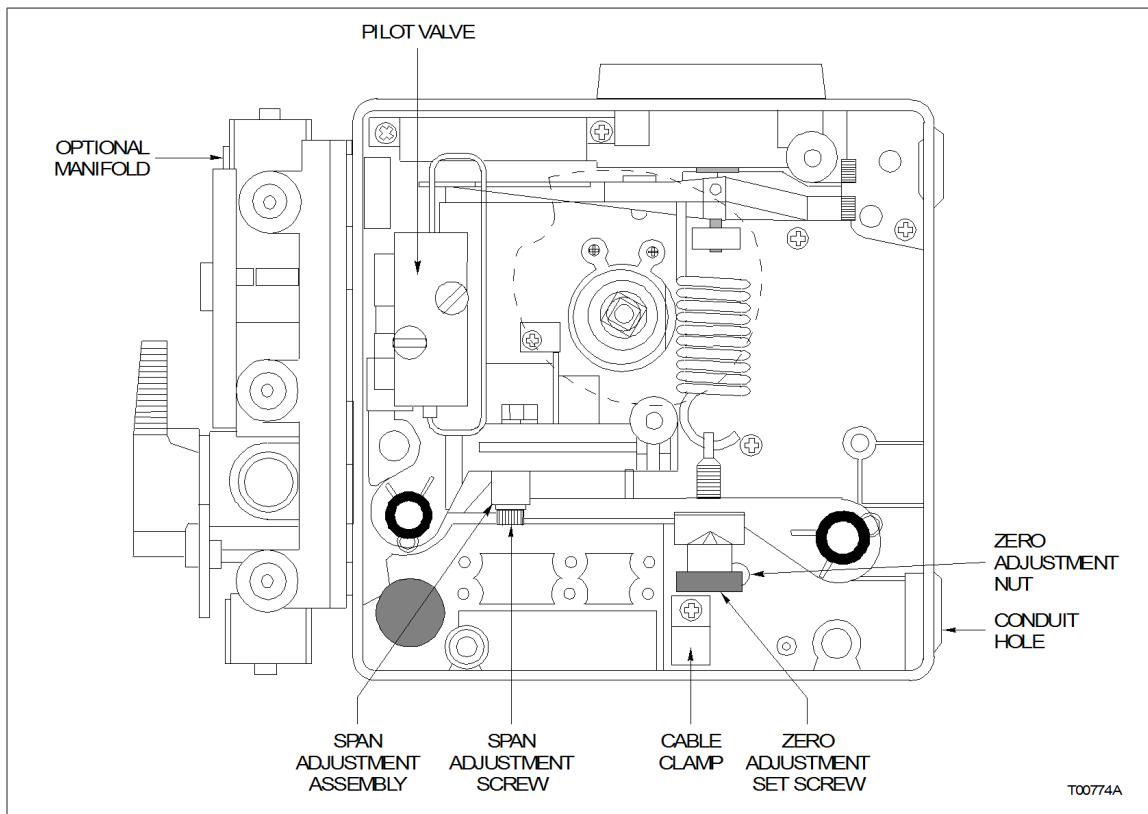

Figure 4-1. Calibration Adjustments

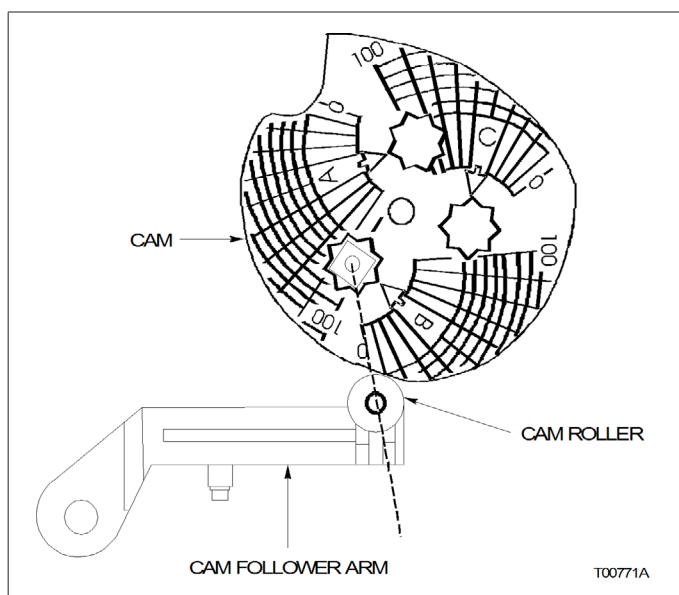

Figure 4-2. Cam Roller Alignment

Span Adjustment

Setting the span normally requires the alignment of the 100 percent radial line of the cam with the center of the cam roller.

Use the following steps to adjust the span:

1. Depending on the nomenclature type, apply one of the following input signals:

- | | |
|---------------------|---|
| Types AV11/5 | Apply 103.4 kPa (15.0 psig). The actuator should move to its fully opened position. |
| Type AV12/6 | Apply 186.2 kPa (27.0 psig). The actuator should move to its fully opened position. |
| Type AV2 | Apply 20 mA. The actuator should move to its fully opened position. |

2. To adjust the span, loosen the span adjustment screw (Fig. 4-1) using a $\frac{3}{32}$ -inch Allen wrench.
3. Slide the span adjustment assembly (Fig. 4-1) in the appropriate direction until the actuator moves to align the 100% radial line with the center of the cam roller (toward pilot valve increases span of actuator).
4. Tighten the span adjustment screw.

CALIBRATION FOR PARTICULAR APPLICATION

The following positioner adjustments may be used to tailor the operation of the actuator to meet application requirements.

Zero Adjustment

The positioner zero adjustment can be used to set initial tension on the range spring so that the actuator will not begin to move from its minimum position until it receives an input signal between zero and 50 percent (Fig. 4-3). This application of suppression is useful when two or more actuators are to be operated in sequence; where the actuator is equipped with a minimum stop; or where the characteristics of the device that the actuator is moving must be matched with the characteristics of another regulated device.

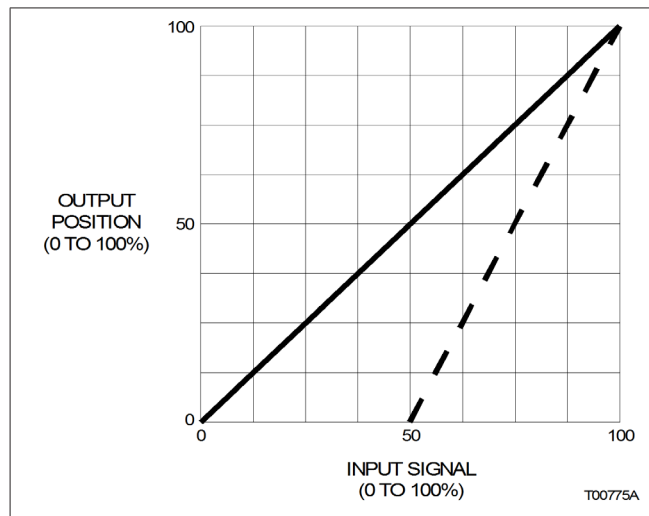

Figure 4-3. Zero Adjustment Graph

Span Adjustment

The span adjustment affords a variation of actuator motion for a given span of input signal. For example, the span may be adjusted to allow full actuator travel to occur with a signal change as small as 50 percent of its full span (e.g., split ranging) (Fig. 4-4). At the other extreme, the span adjustment can be set to produce as little as 50 percent of the travel capability of the actuator over the full input signal pressure span (e.g., short stroking).

This flexibility in span adjustment is useful when the device being regulated is oversized, since the adjustment allows operation of the actuator or cylinder through its useful motion for desired full change in control signal pressure. It is also useful in matching the signal versus position characteristics of the actuator or cylinder with the characteristics of related power devices in the same control system.

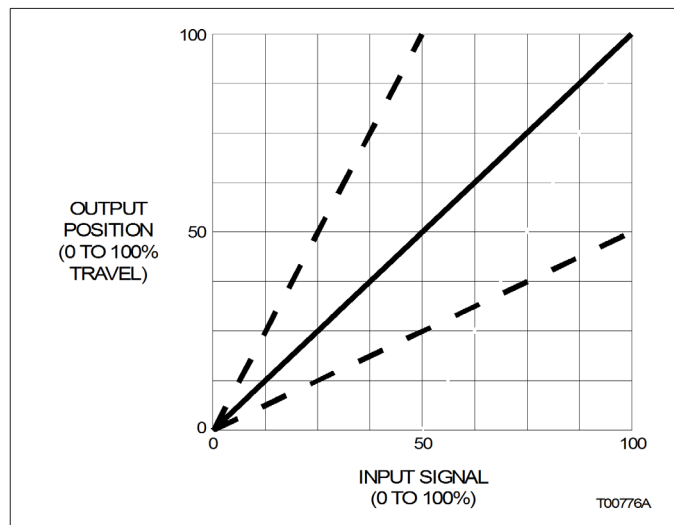

Figure 4-4. Span Adjustment Graph

GAIN AND SPEED ADJUSTMENTS

Gain and speed adjustment information applies to both the Type AV1 and Type AV2 positioners. This is the gain of the overall positioner. The factory-installed 0.25-millimeter (0.100-inch) gain hinge spring suits most applications. This adjustment is not a mandatory part of calibration.

Gain Adjustment

Gain adjustment on the Type AV positioners is accomplished by changing the gain hinge spring (Item 7, Figs. 9-3 or 9-4) connecting the beam assembly to the positioner housing. Provided with each positioner are two different gain hinge springs. If actuator oscillation occurs, the overall positioner gain may be too high. Positioner gain is related to the thickness of the gain hinge spring. Gain decreases as the thickness of the gain hinge spring increases. Refer to Table 4-1 for hinge information.

For information on changing the gain hinge spring, refer to **Gain Hinge Spring** in Section 8.

Table 4-1. Gain Hinge Springs¹

Part Number	Thickness		Gain
	mm	in.	
5400264_1 ²	0.25	0.010	High
5400264_2	0.76	0.030	Medium

NOTES:

1. For small actuators, it may be necessary to combine both gain hinge springs.
2. The high gain hinge spring comes installed from the factory.

Speed Adjustment

Speed adjustment is not normally required when calibrating a positioner. Type AV positioners come from the factory adjusted for maximum operating speed. However, the speed of operation can be reduced in two ways. Speed control orifices can be used to slow positioner operation or a speed adjustment can be made internal to the positioner to change operating speed.

When the system involves only a single actuator, a high positioning speed is usually an advantage. However, in a complex control system, it is generally desirable to operate all power devices at the same speed in order to avoid interaction between units and consequently undesirable process conditions.

ORIFICE

If it is necessary to reduce the speed of operation, 1.02-millimeter (0.04-inch) speed control orifices are available as an option from ABB. These orifices are installed directly into the output ports (01 and 02) of the positioner and have ¼-NPT ports for connecting tubing from the actuator. If these orifices are too small (causing the actuator to respond too slowly) they may be drilled out to obtain desired speed control. Blank orifices are also available. Refer to Table 1-9 for orifice part numbers.

PILOT VALVE STROKE ADJUSTMENT

If it is necessary to reduce the speed of operation, a pilot valve stroke adjustment can reduce the speed and does not require additional hardware. This adjustment limits the pilot valve stroke.

The pilot valve stroke is measured by the movement (displacement) of the pilot valve stem, as shown in Figure 4-5. Figure 4-5 shows the maximum stroke length that is also the maximum speed of operation and is how the positioner comes from the factory. Use the following procedure to reduce the speed of operation:

NOTE: Never adjust the pilot valve for a stroke greater than 0.762 millimeters (0.030 inches) in either direction. A greater stroke will reduce the performance of the positioners.

1. Use a $\frac{3}{32}$ -inch Allen wrench to turn the top adjustment screw clockwise $\frac{1}{8}$ -turn to reduce stroke time (Fig. 4-6). ABB suggests $\frac{1}{8}$ -turn increments. Take note of the number of turns. In total, do not exceed one full turn (clockwise) from the factory setting (Fig. 4-5). This adjustment controls the amount of air going to port 01.

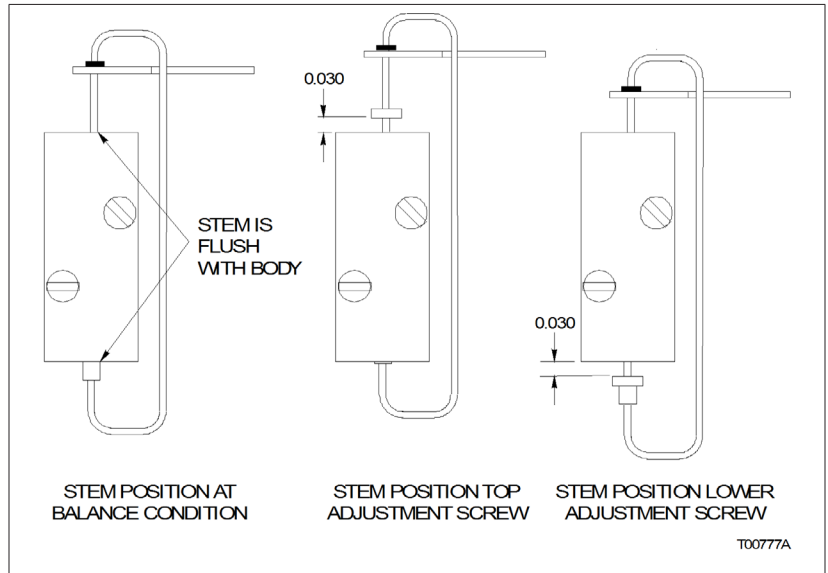

Figure 4-5. Pilot Valve Adjustment

2. Use a $\frac{3}{32}$ -inch Allen wrench (the wrench must be at least 5-inches long) to turn the lower adjustment screw clockwise the same amount as the top adjustment screw to insure speed of operation is the same in both directions (if desired). Be careful when accessing the lower adjustment screw. Insert the Allen wrench up through the bottom of the range spring (Fig. 4-6). This adjustment controls the amount of air going to port 02.

NOTE: To adjust the pilot valve stroke to the factory setting, refer to **PILOT VALVE STROKE ADJUSTMENT** in Section 8.

3. Test for satisfactory stroke time and adjust as required.

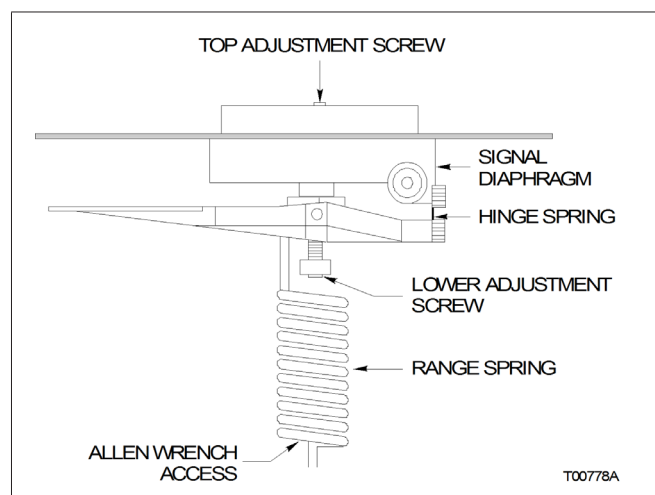

Figure 4-6. Speed Adjustment Screws

TROUBLESHOOTING CALIBRATION ADJUSTMENTS

The I/P converter of the Type AV2 positioner comes from the factory completely calibrated. **Use the following procedures only when operating difficulties occur.** The corrective action column of Table 6-1 indicates when to use the troubleshooting calibration.

The purpose of this procedure is to adjust the I/P converter so that a four to 20-milliamp input signal will produce a 20.7 to 103.4-kilo-pascal (3.0 to 15.0-pounds per square inch gage) signal. Use the following procedure to adjust the I/P converter. The supply air must be connected to the positioner for this procedure.

- Tools Required:**
- Digital voltmeter.
 - Calibrated 0 to 30-psig instrument gage.
 - Small screwdriver.
 - Current source.

CAUTION

Do not exceed the maximum supply pressure of 1034 kilopascals (150 pounds per square inch gage). Exceeding this pressure could cause equipment damage.

1. Connect the calibrated zero to 30-psig instrument gage or other accurate pressure measuring device to the I port to monitor the signal pressure during calibration.
2. Turn on the supply air to the positioner.
3. Provide a four-mA signal to the I/P converter and observe the output pressure. If the pressure equals 20.7 kPa (3.0 psig) go to Step 5. If the pressure does not equal 20.7 kPa (3.0 psig) go to Step 4.
4. Adjust the zero screw ($\rightarrow 0 \leftarrow$) on the bottom of the I/P converter (Fig. 4-7) until the output pressure equals 20.7 kPa (3.0 psig). Clockwise rotation increases pressure.
5. Apply a 20-mA signal to the I/P converter and observe the output pressure. If the pressure equals 103.4 kPa (15.0 psig) go to Step 7. If the pressure does not equal 103.4 kPa (15.0 psig) go to Step 6.
6. Adjust the span screw ($| \leftrightarrow |$) on the bottom of the I/P converter (Fig. 4-7) until the output pressure equals 103.4 kPa (15.0 psig). Clockwise rotation increases pressure.
7. Repeat Steps 3 through 6 until the 20.7 kPa (3.0 psig) and 103.4 kPa (15.0 psig) outputs are attained with four and 20-mA signal inputs.

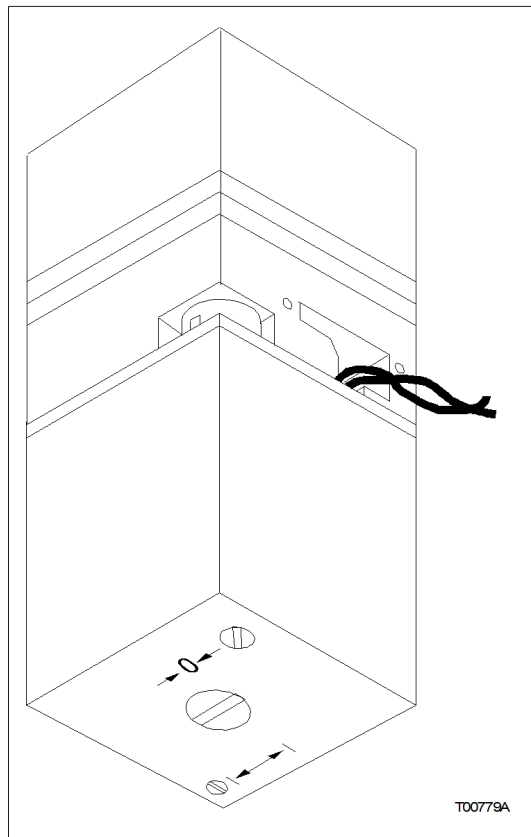

Figure 4-7. I/P Adjustment

SECTION 5 - OPERATING PROCEDURES

INTRODUCTION

This section details the equalizing valve of the optional manifold (Type AV___1___ positioner).

NOTE: This section only applies when the positioner is equipped with a manifold assembly.

EQUALIZING AND AIR SUPPLY SHUTOFF VALVE

The equalizing valve, supplied with the manifold assembly, allows the actuator to be manually or automatically operated. By turning the valve handle to MAN, supply pressure to the positioner is cut off and the 01 and 02 ports are tied together, allowing manual repositioning of the actuator.

NOTE: It is important to understand that the equalizing valve is not a bypass valve. Be aware that if the actuator is not secured before transferring the valve handle of the manifold, the actuator will move.

WARNING	Lock the actuator in place or be aware of the possible movement before moving the equalizing valve to <i>MAN</i> or <i>AUTO</i>. Failure to do so could result in injury to personnel.
----------------	---

Transfer from Automatic to Manual Operation

1. Manually lock the actuator or final control element.
2. If equipped with a manifold and equalizing valve, push in the valve handle and turn it to the MAN position.
3. If not equipped with a manifold and equalizing valve, turn off the supply air.

NOTE: If there are no means of locking the actuator or final control element, it will move in the direction of the process or mechanical load when the supply air is turned off.

Transfer from Manual to Automatic Operation

1. Verify that the valve handle is in the MAN position.

2. If the manual operator does not lock the actuator in position:
 - a. The piston must be positioned from prior knowledge of the actuator position versus signal or the actuator may jump when transferred to automatic.
 - b. Push the valve handle in and turn it to the AUTO position.
3. If the manual operator locks the actuator in position:
 - a. Depress the valve handle and turn it to the AUTO position. The actuator will oppose the manual operator if the drive position and input signal do not correspond.
 - b. Manually operate the actuator until the load on the manual operator decreases. If the output pressure gages are installed on the positioner, the gage readings should equalize.

NOTE: If, in Step 3, it is desired that the drive stay in its initial position, the input signal must be adjusted to correspond with the drive position as indicated by the load on the manual operator, output pressure gages or prior knowledge of position versus input signal.

SECTION 6 - TROUBLESHOOTING

INTRODUCTION

This section provides information about the Type AV positioner when operating difficulties are encountered. A table listing errors, probably causes and corrective actions allows the operator to troubleshoot a problem pertaining to the positioner.

If a problem occurs and is traced to the positioner, check the supply pressure, input and output connections, and mechanical adjustments before removing it from service.

WARNING **Disconnect the supply signal source or remove the equipment from the process before servicing. Failure to do so can cause unexpected movement posing a risk of bodily injury.**

Table 6-1. Positioner Errors

Error	Probably Cause	Corrective Action
Oscillation of actuator	Drive arm not securely attached to actuator.	Tighten or correct linkage as necessary.
	Pneumatic signal leak.	Check for leaks in connectors or fittings.
	Pilot valve sticking.	Remove pilot valve and clean or replace. Refer to Pilot Valve Assembly in Section 8.
	Gain too high.	Change gain hinge spring to greater thickness. Refer to Gain Hinge Spring in Section 8.
Actuator at one end of stroke and does not respond to input change	Air lines in wrong ports.	Check air line connections (Figs. 3-10, 3-11, 3-12, 3-13 and 3-14).
	Incorrect cam installed for application.	Determine application (reverse or direct acting) and check for correct cam (Figs. 3-10, 3-11, 3-12, 3-13 and 3-14).
	Pneumatic signal leak.	AV1: Check input signal connection for leaks at I port. AV2: Check signal at I port. If pressure is between 20.7 and 103.4 kPa (3.0 and 15.0 psig) and responds to input signal change then problem exists elsewhere. If pressure is not between 20.7 and 103.4 kPa (3.0 and 15.0 psig) or does not respond to input change, check for leaks inside positioner and check I/P converter calibration (refer to TROUBLESHOOTING CALIBRATION ADJUSTMENTS in Section 4).
	Mechanical calibration shift.	Make sure the linkage between positioner and actuator is tight and has no backlash.
I/P converter not functioning.	Check I/P converter calibration (refer to TROUBLESHOOTING CALIBRATION ADJUSTMENTS in Section 4).	

TROUBLESHOOTING

Table 6-1. Positioner Errors

Error	Probably Cause	Corrective Action
Excessive air consumption (exhaust loud)	Leakage at the joint of the manifold assembly (if equipped).	Remove manifold and check O-rings. Refer to Manifold in Section 8 .
	Pilot valve body seal is leaking.	Remove pilot valve body and check O-rings. Refer to Pilot Valve Assembly in Section 8 .
	Tubing disconnected.	Check connection at pressure regulator and I/P converter.
Slow response	Signal diaphragm leaking.	Replace signal diaphragm. Refer to Diaphragm Assembly in Section 8 .
	I/P converter out of calibration or not functioning.	Calibrate I/P converter. Refer to TROUBLESHOOTING CALIBRATION ADJUSTMENTS in Section 4 . If unable to calibrate, replace I/P converter. Refer to I/P Converter in Section 8 .
Full range cannot be obtained with mechanical zero and span adjustment	Signal diaphragm leaking.	Replace diaphragm. Refer to Diaphragm Assembly in Section 8 .
	I/P converter out of calibration or not functioning.	Calibrate I/P converter. Refer to TROUBLESHOOTING CALIBRATION ADJUSTMENTS in Section 4 . If unable to calibrate, replace I/P converter. Refer to I/P Converter in Section 8 .
	I/P converter is defective.	Replace I/P converter. Refer to I/P Converter in Section 8 .

SECTION 7 - MAINTENANCE

INTRODUCTION

The reliability of any stand-alone product or control system is affected by the maintenance of the equipment. ABB recommends that all equipment users practice a preventive maintenance program that will keep the equipment operating at an optimum level.

Maintenance personnel should be familiar with the Type AV positioner and have experience working with process control applications that use pneumatic positioners.

WARNING

System maintenance must be performed only by qualified personnel and only after securing the equipment controlled by the circuit. Altering or removing components from an active circuit may upset the controlled process leading to personnel injury and equipment damage.

PREVENTIVE MAINTENANCE SCHEDULE

Table 7-1 is the preventive maintenance schedule and checklist for Type AV positioners. The table lists the preventive maintenance tasks in groups according to their specified maintenance interval. The maintenance intervals are recommendations and may vary depending on the location environment and the air quality of the positioner. As a minimum, these recommended maintenance tasks should be performed during an extended process shutdown.

Some tasks in Table 7-1 are self-explanatory. Instructions for tasks that require further explanation are covered under **PREVENTIVE MAINTENANCE PROCEDURES**.

Table 7-1. Preventive Maintenance Schedule

Preventive Maintenance Tasks	Interval (months)
Check and tighten all wiring connections.	12
Clean or replace supply air filter.	
Clean or replace manifold filters. Refer to procedure.	

Table 7-1. Preventive Maintenance Schedule (continued)

Preventive Maintenance Tasks	Interval (months)
Check all air connections for leakage while positioner is under pressure. Use a soapsuds solution.	12
Check the signal diaphragm for leaks. use a soapsuds solution.	
Clean pilot valve and stem with low residue solvent. Refer to REPAIR AND REPLACEMENT in Section 8.	
Check calibration of positioner and actuator. Refer to Section 4.	
Check and verify that there is no backlash in the linkage/connections between the positioner and the actuator. Refer to Section 3.	

PREVENTIVE MAINTENANCE PROCEDURES

This section covers instructions for cleaning and replacing the manifold filters.

MANIFOLD FILTERS

Tools Required: • Torque screw driver.

WARNING

Lock the actuator in place or be aware of the possible movement before moving the equalizing valve to *MAN* or *AUTO*. Failure to do so could result in injury to personnel.

1. Transfer the positioner from automatic to manual operation (Section 5).
2. After allowing the pressure to bleed off, remove the cover screw securing the filter cover (Fig. 7-1) and set the cover screw and cover aside.
3. Clean or replace the filters.
 - a. To clean the filters, soak them in a low residue solvent. After soaking, spray the filters thoroughly using compressed air until they are free of particles and solvents.
 - b. Insert the clean or new filters, using the filter kit identified in Table 1-7, into the filter wells.
4. Replace and lubricate the three O-rings (Fig. 7-2) using the lubricant supplied in the kit (Dow Corning® No. 4).
5. Clean and place the cover over the filters and replace the cover screw. Torque the cover screw to two Nm (18 in-lbs).

6. Transfer the positioner back to automatic operation (Section 5).

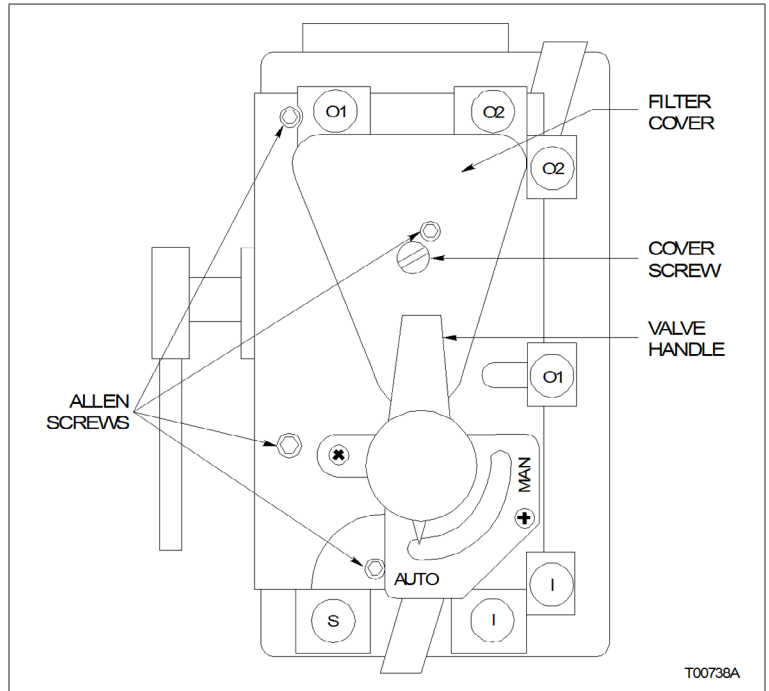

Figure 7-1. Positioner with Manifold

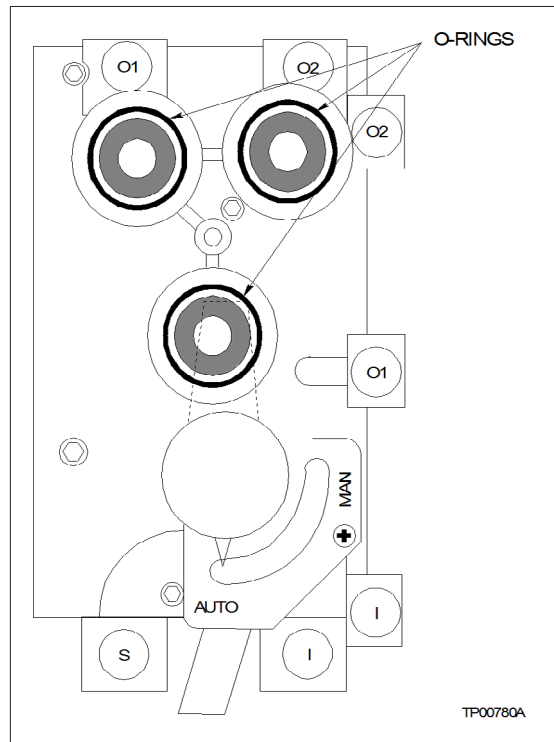

Figure 7-2. Manifold with Filter Cover Removed

SECTION 8 - REPAIR AND REPLACEMENT

INTRODUCTION

This section provides procedures that detail removal and replacement of positioner components.

WARNING

Disconnect the supply signal source or remove the equipment from the process before servicing. Failure to do so can cause unexpected movement posing a risk of bodily injury.

REPLACEMENT PROCEDURES

This section contains replacement procedures for:

- Manifold.
- Gain hinge spring.
- Pilot valve assembly.
- I/P converter.
- Cam.
- Diaphragm assembly.

Manifold

Tools Required:

- Torque screwdriver.
- $\frac{3}{32}$ -inch Allen wrench.

1. Secure (lock) the actuator and remove the supply air.
2. If equipped with an equalizing valve, push in on the valve handle and move it to the MAN position (Fig. 8-1).
3. Remove the four Allen screws that secure the manifold (Fig. 8-1).
4. Lift the manifold off the positioner.
5. Before replacing the manifold, make sure there are no deposits on the bosses of the positioner or on the back of the manifold. If there are, remove the deposits.
6. Replace the O-rings or clean them if they are in good condition (Fig. 8-2).
7. Clean the O-ring grooves and apply Dow Corning No. 4 or equivalent lubricant to the O-rings.

REPAIR AND REPLACEMENT

- Place the manifold in place on the positioner so it properly seats on the bosses.
- Insert the Allen screws and torque them to 3.5 Nm (31 in.-lbs). Not all of the Allen screws are the same length. Be sure each screw mates correctly.
- To replace the filters and filter cover, refer to **MANIFOLD FILTERS** in **Section 7**.

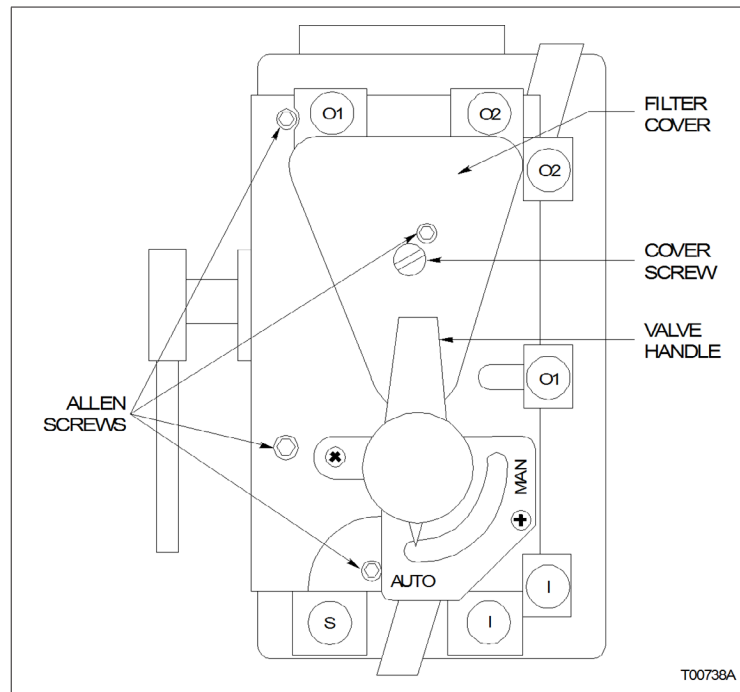

Figure 8-1. Positioner with Manifold

Gain Hinge Spring

NOTES:

- Refer to Table 4-1 for gain hinge spring part numbers.
- Item numbers in this procedure reference Figure 9-3 or 9-4.

Tools Required:

- Flat-tip screwdriver.
- $\frac{3}{64}$ -inch Allen wrench.

- Transfer the positioner from automatic to manual operation (**Section 5**).
- Remove the positioner cover by removing the two cover screws.
- Remove the plug button (Item 29) from the positioner housing. This opening provides access to the screws.

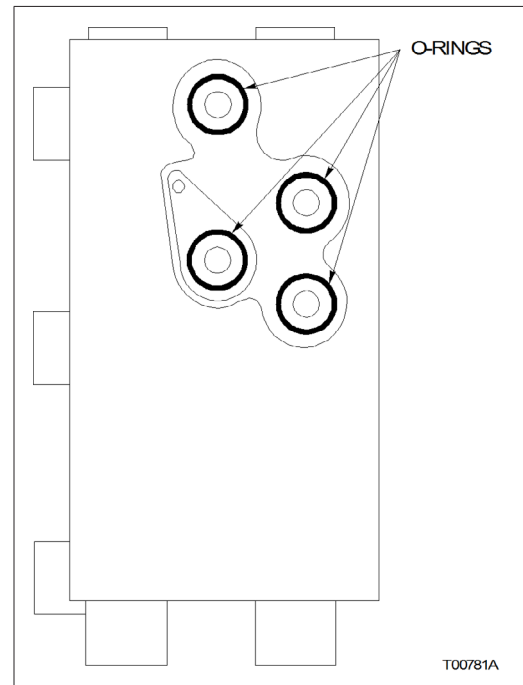

Figure 8-2. Manifold O-Rings

4. Remove the four hinge screws (Item 42) while holding the beam assembly steady (Item 6). Remove the two screws that connect the beam to the hinge first.
5. Remove the gain hinge spring.
6. Insert the new gain hinge spring.

NOTE: When installing the gain hinge spring, be sure it properly seats (flush) between the steps. If the gain hinge spring hangs up, remove and rotate the hinge 90°. Check for proper seating.
7. Insert and torque the screws to 2.6, ± 0.2 Nm (23, ± 2 in.-lbs) while holding the beam assembly steady (Item 6). Insert the two screws that secure the hinge to the housing first.
8. Transfer the positioner back to automatic operation ([Section 5](#)).
9. Perform the procedure outlined in **PILOT VALVE STROKE ADJUSTMENT**.

Pilot Valve Assembly

NOTES:

1. Refer to [Section 9](#) for pilot valve assembly kit numbers.
2. Item numbers in this procedure reference [Figure 9-3](#) or [9-4](#).

REPAIR AND REPLACEMENT

Tools Required: Flat-tip screwdriver.

1. Transfer the positioner from automatic to manual operation ([Section 5](#)).
2. Remove the positioner cover by removing the two cover screws.
3. Carefully unhook the ends of the valve clip (Item 5). Remove the valve clip from the valve body. Remove the valve stem (Item 3) from the lower end of the valve body.
4. Remove the two pilot valve screws (Item 52) securing the valve body and lift the valve body off the housing.
5. Replace the O-rings. Clean the O-ring grooves and apply Dow Corning No. 4 or equivalent lubricant to the O-rings.
6. Set the (replacement or clean) valve body in place.
7. Secure the valve body by replacing and tightening the pilot valve screws to 2.6, ± 0.2 Nm (23, ± 2 in.-lbs).
8. Make certain the valve stem is clean. Install the valve stem.
9. Install the valve clip.
10. Transfer the positioner back to automatic operation ([Section 5](#)).
11. Perform the procedure outlined in **PILOT VALVE STROKE ADJUSTMENT**.

I/P Converter

NOTES:

1. Refer to [Section 9](#) for I/P converter part numbers.
2. Item numbers in this procedure reference Figure 9-4.
3. This procedure only applies to Type AV2 positioners.

Tools Required:

- Flat-tip screwdriver.
- T15 Torx.
- Pliers.

1. Transfer the positioner from automatic to manual operation ([Section 5](#)).
2. Remove the positioner cover by removing the two cover screws.
3. Remove the two wires that connect the I/P converter (Item 80) to the termination assembly (Item 59).
4. Loosen the three screws (Item 58) securing the I/P bracket.

5. Slide the I/P converter out from under the screws and remove it from the housing.
6. Disconnect the two air lines from the I/P converter. When replacing the I/P converter, remove the portion of the air line tubing that was connected to the I/P converter or replace the tubing. If this is not done, particles from the tubing can cause a blockage.
7. Reverse the preceding steps to install the new I/P converter.

Cam

NOTE: Item numbers reference Figure 9-3.

Tools Required:

- Flat-tip screwdriver.
 - Adjustable wrench.
 - Pliers.
1. Transfer the positioner from automatic to manual operation (Section 5).
 2. Remove the positioner cover by removing the two cover screws.
 3. Remove the indicator screw (Item 51) and indicator (Item 19).
 4. Hold and stop the cam shaft from rotating if it is not secured by linkage or coupling. Using the adjustable wrench, remove the cam nut (Item 30) and washer (Item 55).
 5. Lift the cam from the cam shaft.
 6. To replace the cam, determine which cam mounting hole (A, B or C) is appropriate for the application, and set the cam on the shaft. Make certain the star-shaped hole engages squarely on the shaft. Refer to Figure 3-8 to align the cam.
 7. Replace the cam washer and nut and tighten.
 8. Set the indicator on the cam shaft and insert and tighten the screw.
 9. Transfer the positioner back to automatic operation (Section 5).

Diaphragm Assembly

NOTES:

1. Refer to Section 9 for diaphragm assembly kit numbers.
2. Item numbers in this procedure reference Figure 9-3 or 9-4.

DIAPHRAGM ASSEMBLY REMOVAL

Tools Required:

- Allen wrench.
- Adjustable wrench.

1. Transfer the positioner from automatic to manual operation ([Section 5](#)).
2. Using an Allen wrench, remove the four diaphragm cover screws (Item 45) and remove the diaphragm cover.
3. Remove the diaphragm support screw (Item 53) and washer (Item 54).

NOTE: When removing the diaphragm support screw, do not allow the diaphragm support (Item 23) to rotate.

NOTE: Item 53 is replaced by SEM screw NBMHA13006A as of November 23, 2009/Serial Number 3K620000029936 & Item 54 is no longer used.

4. Remove the diaphragm support (Item 23).
5. Carefully remove the large diaphragm (Item 73) from assembly.
6. Remove the diaphragm spacer (Item 22).
7. Remove the diaphragm ring (Item 24).
8. Carefully remove the small diaphragm.

DIAPHRAGM ASSEMBLY REPLACEMENT

1. Place the small diaphragm (Item 20) in the diaphragm housing with the concave side facing up. Check for correct alignment of the tabs relative to the diaphragm housing.
2. Place the diaphragm ring (Item 24) over the small diaphragm (Item 20). Make sure the alignment pins on the diaphragm ring properly engage the other mating parts.
3. Set the diaphragm spacer in place (Item 22).
4. Place the large diaphragm (Item 73) in place with the convex side up. Check for correct alignment of the tabs relative to the diaphragm housing.
5. Place the diaphragm support (Item 23) on the large diaphragm.

6. Replace the washer (Item 54) and screw (Item 53). Torque the screw to 0.35 Nm (50 in.-oz.) while securing the diaphragm support (Item 23) so it does not rotate.

NOTE: Item 53 is replaced by SEM screw NBMHA13006A as of November 23, 2009/Serial Number 3K620000029936 & Item 54 is no longer used.

7. Inspect the diaphragm assembly for distortion. If distortion occurs loosen the screw (Item 53), straighten the diaphragm and tighten while holding Item 23 still.

8. Replace the diaphragm cover (Item 25) and screws (Item 45). Make certain the diaphragm cover is properly seated. Torque the cover screws uniformly to 0.9 Nm (8 in.-lbs).

9. Transfer the positioner back to automatic operation ([Section 5](#)).

10. Apply the input signal pressure and check for leaks around the diaphragm assembly using soapsuds solution.

11. Perform the procedure outlined in **PILOT VALVE STROKE ADJUSTMENT**.

PILOT VALVE STROKE ADJUSTMENT

The purpose of this adjustment is to keep the valve stem in the proper operating range. This procedure should be used in conjunction with the following procedures:

- **Gain Hinge Spring.**
- **Pilot Valve Assembly.**
- **Diaphragm Assembly.**

NOTE: For internal speed adjustment refer to **PILOT VALVE STROKE ADJUSTMENT** in [Section 4](#).

When the valve stem is in the balance position, as shown in [Figure 8-3](#), the stem is flush with both ends of the valve body. There are two adjustment screws to adjust. Use the following procedure to check and adjust the travel of the valve stem:

Tools required:

- $\frac{3}{32}$ -inch Allen wrench (standard length).
- $\frac{3}{32}$ -inch Allen wrench (long length — at least five inches).

1. With the positioner cam at approximately 50%, manually lock the actuator in position by:

- a. Using manual override if available.

- or -

REPAIR AND REPLACEMENT

- b. If manual override is not available, disconnect (and secure) the linkage. Plug ports 01 and 02 if necessary.
2. Apply the supply pressure.
3. Apply the maximum input signal to the positioner:
 - AV11: 103.4 kPa (15.0 psig).
 - AV12: 186.2 kPa (27.0 psig).
 - AV23: 20 mA.
4. Use the long $\frac{3}{32}$ -inch Allen wrench, adjust the top adjustment screw (Fig. 8-4) appropriately until the measurement matches the value shown in Figure 8-3. Figure 8-3 also shows the way the measurement is taken.
5. Apply the minimum input span to the positioner:
 - AV11: 20.7 kPa (3.0 psig).
 - AV12: 20.7 kPa (3.0 psig).
 - AV23: 4 mA.
6. Use the long $\frac{3}{32}$ -inch Allen wrench to adjust the lower stroke adjustment screw (Fig. 8-4). Adjust the screw until the measurement matches the value shown in Figure 8-3.

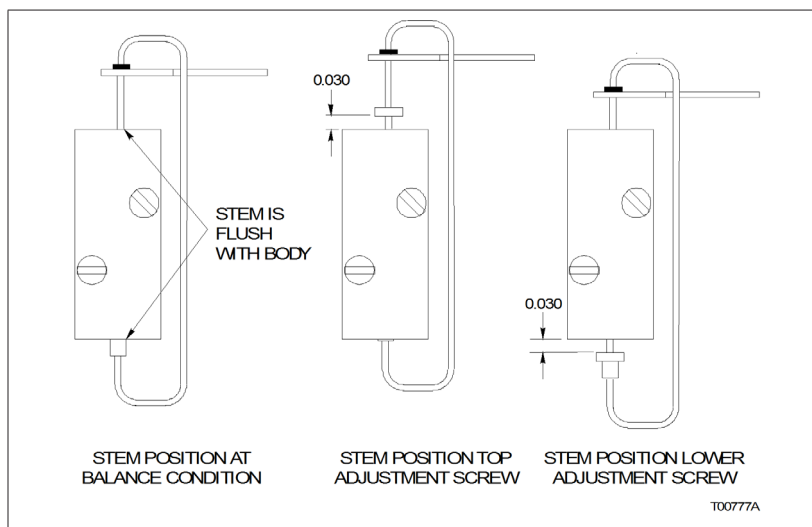

Figure 8-3. Pilot Valve Measurement for Maximum Speed

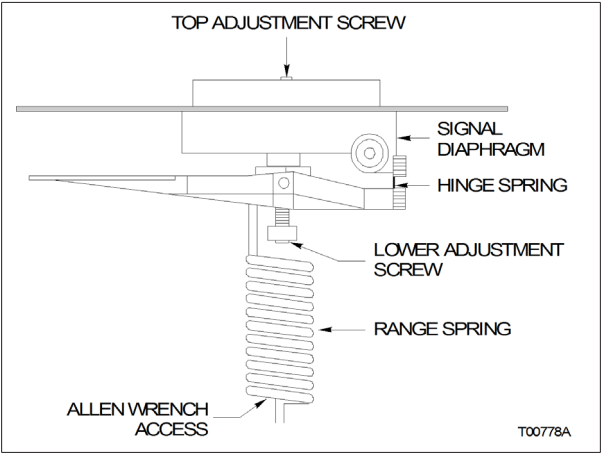

Figure 8-4. Stroke Adjustment Screws

SECTION 9 - SUPPORT SERVICES

INTRODUCTION

This section provides:

- Recommended spare parts** A list of the parts that should be kept on hand so that if malfunctions occur, replacements are quickly accessible.
- Additional spare parts** A list of parts that can be ordered for replacement.
- Positioner illustrations** Illustrations that point out all major components of the Type AV1 and AV2 positioners. A parts list is included along with part numbers.

RECOMMENDED SPARE PARTS

ABB suggests that the following items be kept on hand in case replacement is necessary. To order, call your nearest ABB sales representative; supply the kit numbers or if the items are not of a kit, supply the part numbers.

NOTE: This is not a complete list of available parts; refer also to in this section and Table 1-7 in Section 1.

*Table 9-1. Shutoff Valve Kit No. 258270_1
(positioners equipped with optional manifold, Type AV__ 1/2 __)*

Description	Part No.	Quantity
Shutoff valve	5400060_1	1

*Table 9-2. AV Diaphragm Assembly Kit No. 258486_1¹
(for Types AV11 and AV12)*

Item	Part No.	Qty	Description	Item	Part No.	Qty	Description
20	5400288_2	1	Small diaphragm	24	5400294_1	1	Diaphragm ring
22	5400292_1	1	Diaphragm spacer	73	5400288_1	1	Large diaphragm (AV11)
23	5400293_1	1	Diaphragm support (AV11)	73	5400283_3	1	Large diaphragm (AV12)
23	5400293_2	1	Diaphragm support (AV12)				

NOTE: ¹ Kit contains SEM screw NBMMA13006A as of November 2009/Serial Number 3K620000029936.

*Table 9-3. AV Diaphragm Assembly Kit No. 258486_2 ¹
(for Types AV15 and AV16)*

Item	Part No.	Qty	Description	Item	Part No.	Qty	Description
20	5400288_5	1	Small diaphragm	24	5400294_1	1	Diaphragm ring
22	5400292_1	1	Diaphragm spacer	73	5400288_4	1	Large diaphragm (AV15)
23	5400293_1	1	Diaphragm support (AV15)	73	5400283_6	1	Large diaphragm (AV16)
23	5400293_2	1	Diaphragm support (AV16)				

NOTE: ¹ Kit contains SEM screw NBMMA13006A as of November 2009/Serial Number 3K620000029936.

*Table 9-4. Filter Replacement Kit No. 258487_1
(positioners equipped with optional manifold, Type AV___1/2___)*

Part No.	Qty	Description
19984_1	1	O-ring lubricant
5311428_1	3	O-rings
5400057_1	3	Filters

*Table 9-5. Pilot Valve Assembly Kit No. 258488_1
(for Types AV11, AV12 and AV2)*

Item	Part No.	Qty	Description
3	5400259_1	1	Valve stem
4	5400260_1	1	Valve body
5	5400261_1	1	Valve clip
35	1951398_12	3	O-rings
—	19984_1	1	O-ring lubricant

*Table 9-6. Pilot Valve Assembly Kit No. 258488_2
(for Types AV15 and AV16)*

Item	Part No.	Qty	Description
3	5400259_1	1	Valve stem
4	5400260_1	1	Valve body
5	5400261_1	1	Valve clip
35	1951779_010	3	O-rings
—	19984_1	1	O-ring lubricant

*Table 9-7. Pilot Valve Assembly Kit No. 258488_3
(for Types AV11___P, AV12___P and AV2___P)*

Item	Part No.	Qty	Description
3	5400259_1	1	Valve stem
4	5400260_2	1	Valve body
5	5400261_1	1	Valve clip
35	1951398_12	3	O-rings
—	19984_1	1	O-ring lubricant

*Table 9-8. Pilot Valve Assembly Kit No. 258488_4
(for Types AV15_0/3___P and AV16_0/3___P)*

Item	Part No.	Qty	Description
3	5400259_1	1	Valve stem
4	5400260_2	1	Valve body
5	5400261_1	1	Valve clip
35	1951779_010	3	O-rings
—	19984_1	1	O-ring lubricant

*Table 9-9. Cam
(select appropriate cam type)*

Part No.	Qty	Description
5400281_1	1	Forward acting full rise cam, 90° rotation
5400281_2	1	Reverse acting full rise cam, 90° rotation
5400289_1	1	Forward acting half rise cam, 45° rotation
5400289_2	1	Reverse acting half rise cam, 45° rotation

ADDITIONAL SPARE PARTS

Table 9-10. AV2 I/P Assembly Kit No. 258651_1

Part No.	Qty	Application	Description
258651_1	1	AV2	I/P converter kit

Table 9-11. Gain Hinge Springs¹

Item	Part No.	Qty	Thickness		Gain
			mm	in.	
7	5400264_1 ²	1	0.25	0.010	High
	5400264_2	1	0.76	0.030	Medium

NOTES:

1. For small actuators, it may be necessary to combine both gain hinge springs.
2. The high gain hinge spring comes installed from the factory.

SUPPORT SERVICES

*Table 9-12. Manifold Assembly Kit No. 258491_1
(replaces 5400282_1 or 5400282_2 (for replacement or field addition, Type AV___1/2___))*

Item	Part No.	Qty	Description	Item	Part No.	Qty	Description
17	5400282_1	1	Manifold assembly	67	NBAHA16024	2	Manifold screws
64	5311428_207	4	Manifold O-rings	—	19984_1	1	O-ring lubricant
65	NTJHA09030	4	Manifold washers	—	5400066_1	1	Valve plate ¹
66	NBAHA16020	4	Manifold screws				

NOTE:

1. Used to make equalizing valve handle inoperable for Type AV___2___positioner applications. Discard for Type AV1___1___positioner applications.

*Table 9-13. Cam Follower Arm Kit No. 258544_1
(replaces part no. 5400306_1)*

Part No.	Qty	Description
258544_1	1	Cam Follower- Arm Assembly

*Table 9-14. Cover Assembly Kit No. 258545_1
(for Types AV11, AV12 and AV2 — replaces part no. 5400258_1)*

Item	Part No.	Qty	Description	Item	Part No.	Qty	Description
1	5400254_1	1	Cover	4	5400257_1	1	Cover insert
2	5400255_1	1	Window	5	5400257_2	1	Cover insert
3	5400256_1	1	Gasket	6	1964033_1	1	Styleplate

*Table 9-15. Cover Assembly Kit No. 258545_1
(for Types AV15 and AV16 — replaces part no. 5400258_1)*

Item	Part No.	Qty	Description	Item	Part No.	Qty	Description
1	5400254_1	1	Cover	5	5400257_2	1	Cover insert
2	5400255_1	1	Window	6	1964033_1	1	Styleplate
4	5400257_1	1	Cover insert	10	R9025-0046	1	Silicon tubing

*Table 9-16. Gage Block Assembly Kit No. 258569_1
(for replacement or field addition, Types AV11___3, AV12___3 and AV2___3)*

Item	Part No.	Qty	Description	Item	Part No.	Qty	Description
1	5400318_1	1	Manifold, gage	6	5311428_207	4	O-rings
2	NKJHA16004	3	Set screw, socket hex hdss cup pnt	7	NBAHA16020	3	Screw, hex socket head cap
5	1951041_4	2	Pipe plug, socket head	8	NTJHA09030	3	Lockwasher, spring

*Table 9-17. Gage Block Assembly Kit No. 258569_3
(for replacement or field addition, Types AV15_3 and AV16)_3)*

Item	Part No.	Qty	Description	Item	Part No.	Qty	Description
1	5400318_1	1	Manifold, gage	6	1951779_207	4	O-rings
2	NKJHA16004	3	Set screw, socket hex hdss cup pnt	7	NBAHA16020	3	Screw, hex socket head cap
5	1951041_4	2	Pipe plug, socket head	8	NTJHA09030	3	Lockwasher, spring

*Table 9-18. Potentiometer
(for potentiometric position transmitters (Type AV____1____))*

Part No.	Qty	Description
6639540_1	1	Potentiometer assembly

*Table 9-19. 4 to 20-mA Position Transmitter Circuit Board
(Type AV____2____)*

Part No.	Qty	Description
6639479_1	1	Circuit board

*Table 9-20. Positioner Mounting Kit Number 5327321_12¹
Valve Stem Diameter 0.375 to 0.750 in. (Fig. 9-1)*

Item	Part Number	Description	Item	Part Number	Description
1	5400266_1	Positioner mounting bracket	12	197120_5	Nut, elastic stop (2 req)
2	0.250-20 x 0.750	Screw, socket head (3 req)	13	5311690_1	Adjustable stud, 2.69 in.
3	0.250	Lock washer, reg spring (3 req)	14	5311690_2	Adjustable stud, 3.43 in.
5	0.312-18 x 0.625	Cap screw, hex socket head (2 req)	21	0.375	Lock washer, med spring (3 req)
6	0.312	Lock washer, reg spring (2 req)	22	0.375-24	Nut, hex jam
7	R6440-005	Type 347 stainless steel wire, 0.300 diameter, 6-in. length	23	5311687_2	Stem clamp, 0.375 - 0.750-in. dia
8 ²	19934_248	Spacer	25	5311691_1	Clamp plate, 0.375 - 0.750-in. dia
9 ²	0.190-32 x 1.125	Screw, pan head machine	27	0.375-16 x 1.50	Screw, hex skt head cap (2 req)
10	5312449_4	Connecting link, 12-in. length (cut to fit)	28	0.375-16	Nut, hex jam (2 req)
11 ³	0.190-32 x 0.875	Screw, pan head machine (2 req)	29	0.125 dia x 0.750	Groove pin, type 1

NOTES:

1. Positioner mounting kits for direct or reverse acting diaphragm actuators and single or double acting piston actuators with linear (reciprocating) motion.
2. When fastening Item 10 to the drive arm at the first hole (nearest the drive shaft), use Items 8 and 9 and omit one of Item 11.

SUPPORT SERVICES

Table 9-21. Positioner Mounting Kit Number 5327321_13¹
Valve Stem Diameter 0.750 to 1.000 in. (Fig. 9-1)

Item	Part Number	Description	Item	Part Number	Description
1	5400266_1	Positioner mounting bracket	11 ³	0.190-32 x 0.875	Screw, pan head machine (2 req)
2	0.250-20 x 0.750	Screw, socket head (3 req)	12	197120_5	Nut, elastic stop (2 req)
3	0.250	Lock washer, reg spring (3 req)	14	5311690_2	Adjustable stud, 3.43 in.
5	0.312-18 x 0.625	Cap screw, hex socket head (2 req)	21	0.375	Lock washer, med spring (3 req)
6	0.312	Lock washer, reg spring (2 req)	22	0.375-24	Nut, hex jam
7	R6440-005	Type 347 stainless steel wire, 0.300 diameter, 6-in. length	24	5312483_1	Stem clamp, 0.750 - 1.00-in. dia
8 ²	19934_248	Spacer	26	5312471_1	Clamp plate, 0.750 - 1.00-in. dia
9 ²	0.190-32 x 1.125	Screw, pan head machine	27	0.375-16 x 1.50	Screw, hex skt head cap (2 req)
10	5312449_4	Connecting link, 12-in. length (cut to fit)	29	0.125 dia x 0.750	Groove pin, type 1

NOTES:

1. Positioner mounting kits for direct or reverse acting diaphragm actuators and single or double acting piston actuators with linear (reciprocating) motion.
2. When fastening Item 10 to the drive arm at the first hole (nearest the drive shaft), use Items 8 and 9 and omit one of Item 11.

Table 9-22. Positioner Mounting Kit Number 5327321_14¹ (for use on Fisher Actuators)
Valve Stem Diameter 0.375 to 0.750 in. (Fig. 9-1)

Item	Part Number	Description	Item	Part Number	Description
1	5400266_1	Positioner mounting bracket	11 ²	0.190-32 x 0.875	Screw, pan head machine (2 req)
2	0.250-20 x 0.750	Screw, socket head (3 req)	12	197120_5	Nut, elastic stop (2 req)
3	0.250	Lock washer, reg spring (3 req)	15	5319500_11	Drive stud, 4.59 in.
5	0.312-18 x 0.625	Cap screw, hex socket head (2 req)	16	5319500_1	Drive stud, 3.43 in.
6	0.312	Lock washer, reg spring (2 req)	17	5328155_1	Stud bracket
7	R6440-005	Type 347 stainless steel wire, 0.300 diameter, 6-in. length	18	0.312-18 x 0.500	Screw, hex head cap (2 req)
8 ²	19934_248	Spacer	19	1218-00	Lock washer, shakeproof (2 req)
9 ²	0.190-32 x 1.125	Screw, pan head machine	20	5319524_1	Lock washer, star
10	5312449_4	Connecting link, 12-in. length (cut to fit)			

NOTES:

1. Positioner mounting kits for direct or reverse acting diaphragm actuators and single or double acting piston actuators with linear (reciprocating) motion.
2. When fastening Item 10 to the drive arm at the first hole (nearest the drive shaft), use Items 8 and 9 and omit one of Item 11.

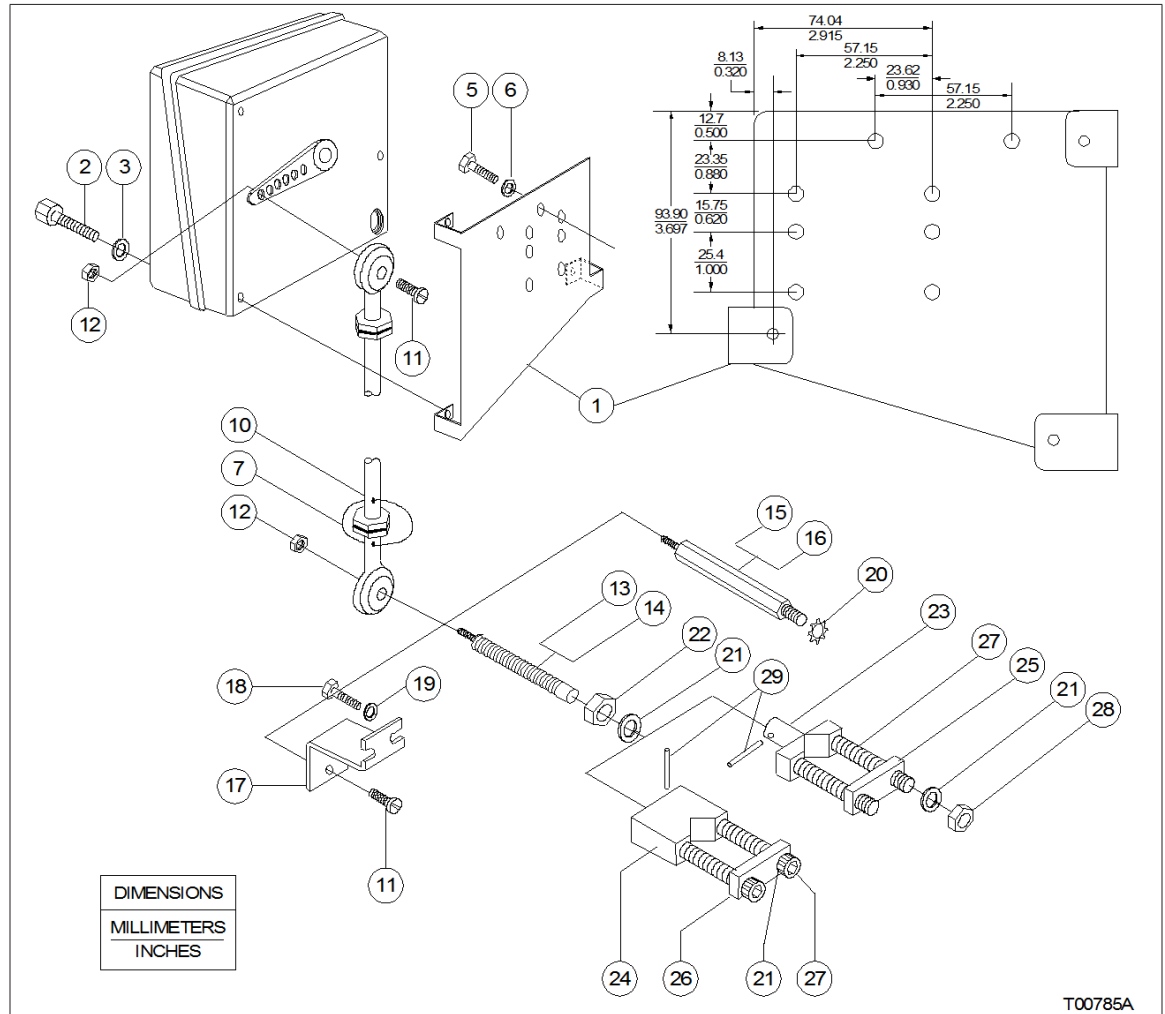

Figure 9-1. Mounting Kits

Table 9-23. Rotary Actuator Retrofit Mounting Kits

Kit Number	Drive Nomenclature	Retrofit Mounting Kit
5400309_1	UP1, UP2	Type AP positioner to Type AV positioner
258493_1	UP3, UP4	
258494_1	UP5, UP6	
258527_1	AC0404	
258528_1	AC0608	
258529_1	AC0816	
258530_2	AC1016	ABB part number pilot valve positioner to Type AV positioner
258527_1	AC0404	
258528_1	AC0608	
258529_1	AC0816	
258530_1	AC1016	

*Table 9-24. Bypass Valve Assembly (Optional)
Parts List (Part No. 5326945_1 — Fig. 9-2)*

Item	Part Number	Description
1	5327226_1	3-way valve
2	5326946_1	Air line connection assy
3	195159_3	Elbow connector
4	195727_2	Brass nipple
5	195171_3	Weatherhead tee
6	1962833_1	Designation plate
7	NBZAC16006	Screw, pan head
8	NTJAC09030	Lock washer
9	NLMAC16000	Nut, hex
10	1951041_1	Sch pipe plug

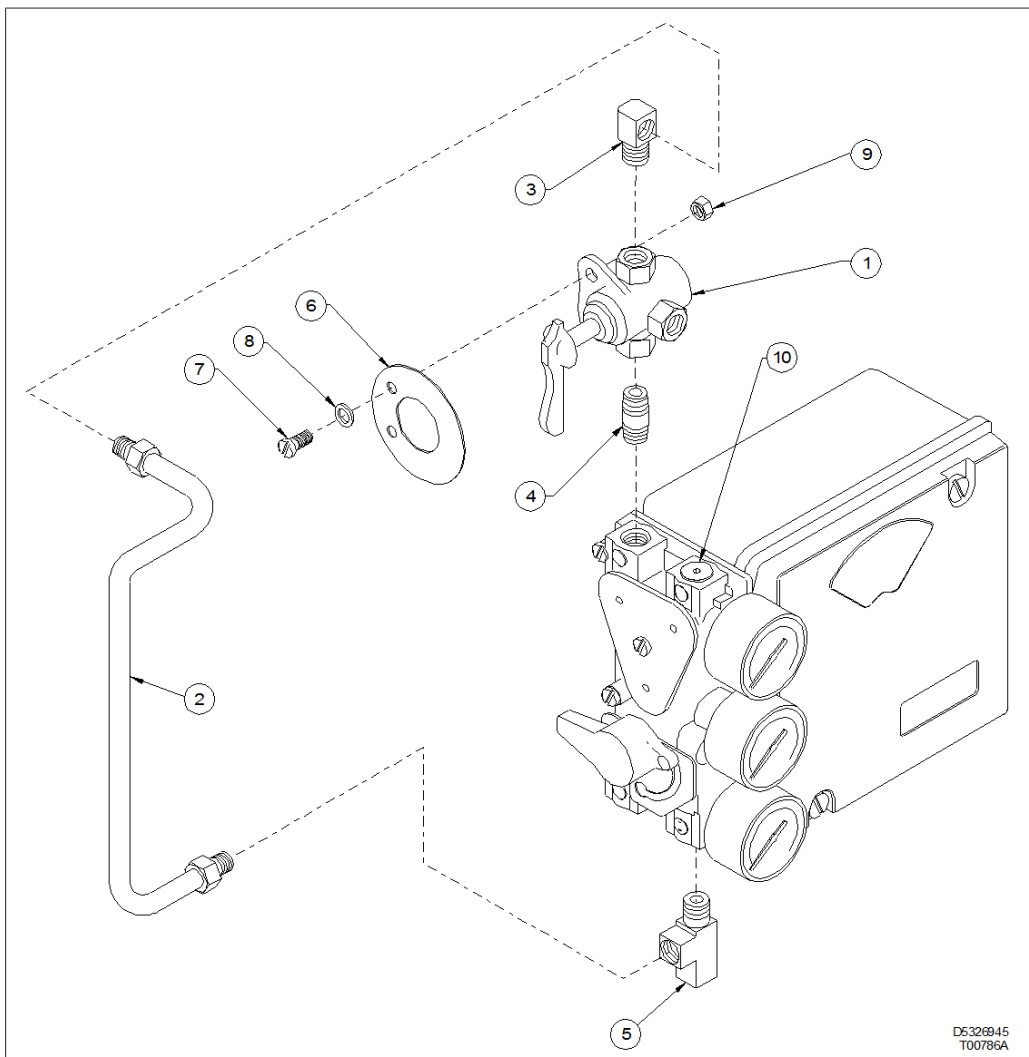

Figure 9-2. Bypass Valve Assembly

Table 9-25. Type AV1 Positioner Parts List for Figure 9-3

Item	Part No.	Description	Item	Part No.	Description
1	5400253_3	Housing	46	197865_2	Stroke adjustment screw
2	Refer to Table 9-26	Cover assembly	47	197865_1	Stroke adjustment screw
3	5400259_1	Valve stem	48	NKJHA16004	Zero adjustment set screw
4	Refer to Table 9-26	Valve body	49	NBAHA16020	Span adjustment screw
5	5400261_1	Valve clip	50	Form MP481-494	Label, CSA/FM ¹
6	5400263_1	Beam assembly	51	NIDHA13005	Indicator screw
7	5400264_1	Hinge	52	NIDHA15012	Pilot valve screw (2 req)
8	258544_1	Cam follower arm assembly	53	NBMHA13006	Diaphragm support screw ²
9	5400271_1	Spring arm	54	NTCHA07000	Diaphragm support scr washer ²
10	5400272_1	Pivot	55	NTGHA10000	Cam washer
11	5400273_1	eyebolt	56	NTJHA09030	Span adjustment washer
12	5400275_1	Retaining nut	57	Fm MP432-889	Label, indicator
13	Refer to Table 9-27	Cam	58	197893_1	Thread forming screws ¹
14	Refer to Table 9-29	Cam shaft	59	6639559_1	Termination assembly ¹
15	5400279_1	Zero adjustment nut	61	MP409-393	Label, terminal block
16	5400280_1	Range spring	62	1963318__	Nameplate, universal
17	Refer to Table 9-27	Manifold assembly	63	Refer to Table 9-29	Drive arm ¹
18	193214_1	Bearing	64	Refer to Table 9-27	Manifold O-ring ¹
19	5400286_1	Indicator	65	NTJHA09030	Manifold washer ¹
20	Refer to Table 9-26	Small diaphragm	66	NBAHA16020	Manifold screw ¹
21	Refer to Table 9-28	Potentiometer assembly	67	NBAHA16024	Manifold screw ¹
22	5400292_1	Diaphragm spacer	68	R9025-0046	Tubing (6.4 cm (2.5 in.))
23	Refer to Table 9-26	Diaphragm support	69	1951651_1	Plug
24	5400294_1	Diaphragm ring	71	193197_1	Span adjustment bearing
25	Refer to Table 9-26	Diaphragm cover	72	114B094U01	Plug button
26	5400296_1	Exhaust mesh	73	Refer to Table 9-26	Large diaphragm
27	193243_1	Large position transmitter gear ¹	74	NDPAC15004	Screw
28	1951652_1	Barb fitting (2 req)	75	NTMHA13000	Lock washer ¹
29	Refer to Table 9-26	Plug button	77	6639479_1	4 to 20-mA pos xmtr assembly ¹
30	197120_28	Cam nut	81	Refer to Table 9-26	Bumper grommet (3 req)
31	19734_45	Washers ¹	82	Refer to Table 9-26	Bumper grommet (2 req)
32	197777_50	Retaining ring, cam (2 req)	83	5400268_2	Bracket, pot mounting ¹
33	197164_18	Retaining ring, span	84	193242_1	Small position xmtr gear ¹
34	197227_1	Special hex head sems screw ¹	86	1943187_1	Cable clip ¹
35	Refer to Table 9-26	O-ring (3 req)	87	MP409-393	Label, connection ¹
36	197843_1	Fastener, push-on, removable	88	MP409-393	Label, position transmitter ¹
37	1945750_1	Pull plug (4 req)	89	5400317_1	Gear adapter ¹
38	5400072_2	Knife base	90	NKJHA13004	Socket head cup pt set screw ¹
39	5400073_1	Knife edge	91	NKJHA16004	Socket head cup pt set screw ¹
40	NBZHA21014	Cover screw	92	1951041_4	Socket head pipe plug ¹
41	NBZHA21040	Cover screw	93	Refer to Table 9-26	O-ring
42	NBAHA15006	Hinge screw (4 req)	94	NKJHA23006	Socket head cup pt set screw ¹
43	NPSHA05000	Hairpin clip (2 req)	95	258567_1	NEMA 4X kit ¹
44	NTBTF13150	Teflon washer (3 req)	96	5400264_2	Hinge
45	NBAHA13006	Diaphragm cover screw (4 req)			

NOTE:

1. Refer to Tables 9-26, 9-27, 9-28 and 9-29 for quantities.

2. Items 53 & 54 replaced by SEM screw NBMHA13006A as of November 23, 2009/Serial Number 3K620000029936

Table 9-26. Input Signal Parts Reference for Type AV1 Positioners (Fig. 9-3)

Type	Item (Part Number)											Item (Quantity)		
	2	4	20	23	25	29	35	73	81	82	93	31	94	95
AV11___0	5400258_1	5400260_1	5400288_2	5400293_1	5400295_1	114B095U01	1951398_12	5400288_1	1951755_1	1951755_2	1951631_206	2	Omit	Omit
AV11___N	5400258_1	5400260_1	5400288_2	5400293_1	5400295_1	1943573_1	1951398_12	5400288_1	1951755_1	1951755_2	1951631_206	2	2	1
AV11___P	5400258_1	5400260_2	5400288_2	5400293_1	5400295_1	114B095U01	1951398_12	5400288_1	1951755_1	1951755_2	1951631_206	2	Omit	Omit
AV12___0	5400258_1	5400260_1	5400288_2	5400293_2	5400295_2	114B095U01	1951398_12	5400288_3	1951755_1	1951755_2	1951631_206	2	Omit	Omit
AV12___N	5400258_1	5400260_1	5400288_2	5400293_2	5400295_2	1943573_1	1951398_12	5400288_3	1951755_1	1951755_2	1951631_206	2	2	1
AV12___P	5400258_1	5400260_2	5400288_2	5400293_2	5400295_2	114B095U01	1951398_12	5400288_3	1951755_1	1951755_2	1951631_206	2	Omit	Omit
AV15___0	5400258_3	5400260_1	5400288_5	5400293_1	5400295_1	1945803_1	1951779_10	5400288_4	1951755_3	Omit	1951799_206	Omit	2	Omit
AV15___N	5400258_3	5400260_1	5400288_5	5400293_1	5400295_1	1943573_1	1951779_10	5400288_4	1951755_3	Omit	1951799_206	Omit	2	1
AV15___P	5400258_3	5400260_2	5400288_5	5400293_1	5400295_1	1945803_1	1951779_10	5400288_4	1951755_3	Omit	1951799_206	Omit	2	Omit
AV16___0	5400258_3	5400260_1	5400288_5	5400293_2	5400295_2	1945803_1	1951779_10	5400288_6	1951755_3	Omit	1951799_206	Omit	2	Omit
AV16___N	5400258_3	5400260_1	5400288_5	5400293_2	5400295_2	1943573_1	1951779_10	5400288_6	1951755_3	Omit	1951799_206	Omit	2	1
AV16___P	5400258_3	5400260_2	5400288_5	5400293_2	5400295_2	1945803_1	1951779_10	5400288_6	1951755_3	Omit	1951799_206	Omit	2	Omit

Table 9-27. Cam Selection and Manifold/Gage Block Parts Reference for Type AV1 Positioners (Fig. 9-3)

Type	Item (Part Number)			Item (Quantity)				
	13	17	64	65	66	67	91	92
AV1_1___	5400289_1,2	—	—	—	—	—	—	—
AV1_2___	5400281_1,2	—	—	—	—	—	—	—
AV11/2_0__	—	Omit	Omit	Omit	Omit	Omit	Omit	Omit
AV11/2_1__	—	5400282_1	5311428_207 (4 req)	4	2	2	Omit	Omit
AV11/2_2__	—	5400282_2	5311428_207 (4 req)	4	2	2	Omit	Omit
AV11/2_3__	—	5400318_1	5311428_207 (4 req)	3	3	Omit	3	3
AV15/6_00__	—	Omit	Omit	Omit	Omit	Omit	Omit	Omit
AV15/6_30__	—	5400318_1	5311428_207 (4 req)	3	3	Omit	3	3

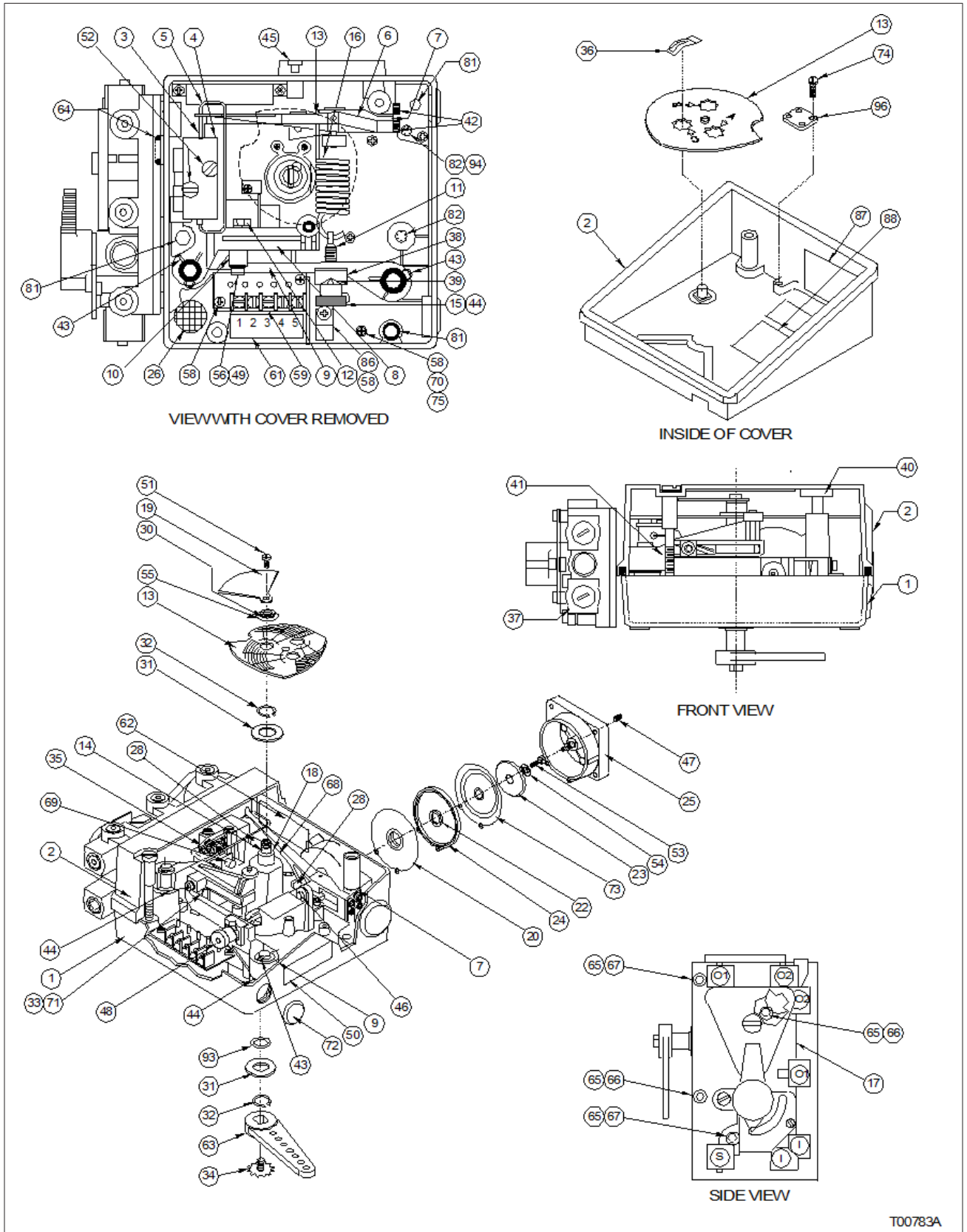

T00783A

Figure 9-3. Type AV1 Positioner

SUPPORT SERVICES

Table 9-28. Shaft Position Transmitter Parts Reference for Type AV1 Positioners (Fig. 9-3)

Type	Item (Part Number)	Item (Quantity)				
	21	27, 50, 59, 61, 75, 83, 84, 86, 87, 89	31	58	77, 78	90
AV1___0__	Omit	Omit	—	Omit	Omit	Omit
AV1___1__	6639542_2	1	3+1	6	Omit	2
AV1___2__	6639542_1	1	3 +1	8	1	2

Table 9-29. Drive Shaft Parts Reference for Type AV1 Positioners (Fig. 9-3)

Type	Item (Part Number)		Item (Quantity)
	14	63	34
AV1_1__0_	5400287_1	5327445_2	1
AV1_2__0_	5400287_1	5327445_1	1
AV1____1_	5400278_1	Omit	Omit
AV1____2_	5400287_2	Omit	Omit
AV1____3_	5400287_3	Omit	Omit
AV1____4_	5400287_4	Omit	Omit
AV1____5_	5400287_5	Omit	Omit

Table 9-30. Type AV2 Positioner Parts List for Figure 9-4

Item	Part No.	Description	Item	Part No.	Description
1	5400253_3	Housing	54	NTCHA07000 ²	Diaphragm support scr washer
2	5400258_1	Cover assembly	55	NTGHA10000	Cam washer
3	5400259_1	Valve stem	56	NTJHA09030	Span adjustment washer
4	Refer to Table 9-31	Valve body	57	Form MP432-889	Label, indicator
5	5400261_1	Valve clip	58	197893_1	Thread forming screw (8 req)
6	5400263_1	Beam assembly	59	6639559_1	Termination assembly
7	5400264_1	Hinge	61	197893_1	Label, CSA/FM
8	258544_1	Cam follower arm assembly	62	1963318__	Nameplate, universal
9	5400271_1	Spring arm	63	Refer to Table 9-31	Drive arm ¹
10	5400272_1	Pivot	64	5311428_207	Manifold O-ring ¹
11	5400273_1	Eyebolt	65	NTJHA09030	Manifold washer ¹
12	5400275_1	Retainer nut	66	NBAHA16020	Manifold screw ¹
13	Refer to Table 9-31	Cam	67	NBAHA16024	Manifold screw ¹
14	Refer to Table 9-31	Cam shaft	68	R9025-0046	Tubing (50.8 cm (20.0 in.))
15	5400279_1	Zero adjustment nut	70	NIDHA09005	Pan head sems screw
16	5400280_1	Range spring	71	193197_1	Span adjustment bearing
17	Refer to Table 9-32	Manifold assembly	72	1943187_1	Cable clip
18	193214_1	Bearing	73	5400288_1	Large diaphragm
19	5400286_1	Indicator	74	114B094U01	Plug
20	5400288_1	Small diaphragm	75	1951655_1	Brass fitting (1 req)
21	Refer to Table 9-33	Potentiometer assembly	76	5400989_2	I/P bracket
22	5400292_1	Diaphragm spacer	77	5400304_1	I/P support
23	5400293_1	Diaphragm support	78		
24	5400294_1	Diaphragm ring	79		

ADDITIONAL SPARE PARTS

Table 9-30. Type AV2 Positioner Parts List for Figure 9-4 (continued)

Item	Part No.	Description	Item	Part No.	Description
25	5400295_1	Diaphragm cover	80	07958063	I/P converter
26	5400296_1	Exhaust mesh	81	1943187_2	Cable clip (2 req)
27	193243_1	Large position transmitter gear	82	NDPAC15004	Pan head screw
28	1951652_1	Barb fitting (2 req)	83	1951747_1	T-fitting
29	Refer to Table 9-31	Plug button	84		
30	197120_28	Cam nut	85	197860_1	Cable strap
31	19734_45	Washers ¹	86	MP409-393	Label, terminal block
32	197777_50	Retaining ring, cam (2 req)	88	6638288_1	Barb fitting filter
33	197164_18	Retaining ring, span	90	MP409-393	Connection label
34	197227_1	Special hex head sems screw	91	6639479_1	4 to 20-mA position xmtr assy ¹
35	1951398_12	O-ring (3 req)	92	197893_1	Thread forming screw ¹
36	197843_1	Fastener, push-on, removable	93	R9023-0205	Heat shrink tubing
37	1945750_1	Pull plug (3 req)	94	1946162_4	Pin receptacle
38	5400072_2	Knife base	95	5400268_2	Bracket, pot mounting ¹
39	5400073_1	Knife edge	96	193242_1	Small position transmitter gear ¹
40	NBZHA21014	Cover screw	98	1951755_1	Bumper grommet (3 req)
41	NBZHA21040	Cover screw	99	1951755_2	Bumper grommet (2 req)
42	NBAHA15006	Hinge screw (4 req)	100	NTMHA13000	Lock washer
43	NPSHA05000	Hairpin clip (2 req)	101	MP409-393	Label, position transmitter ¹
44	NTBTF13150	Teflon washer (3 req)	102	197893_1	Thread forming screw ¹
45	NBAHA13006	Diaphragm cover screw (4 req)	103	5400317_1	Gear adapter ¹
46	197865_2	Stroke adjustment screw	104	NKJHA13004	Socket head cup pt set screw ¹
47	197865_1	Stroke adjustment screw	105	NKJHA16004	Socket head cup pt set screw ¹
48	NKJHA16004	Zero adjustment set screw	106	1951041_4	Socket head pipe plug ¹
49	NBAHA16020	Span adjustment screw	107	NKJHA23006	Socket head cup pt set screw ¹
50	1951041_1	Socket head pipe plug	108	1951631_206	O-ring
51	NIDHA13005	Indicator screw	109	258567_1	NEMA 4X kit ¹
52	NIDHA15012	Pilot valve screw (2 req)	110	5400264_2	Hinge
53	NBMHA13006	Diaphragm support screw ²			

NOTE:

1. Refer to Tables 9-31, 9-32 and 9-33 for quantities.
2. Items 53 & 54 replaced by SEM screw NBMHA13006A as of November 23, 2009/Serial Number 3K620000029936

Table 9-31. Cam and Drive Shaft Parts Reference for Type AV2 Positioners (Fig. 9-4)

Type	Item (Part Number)					Item (Quantity)			
	4	13	14	29	63	31 ¹	34	107	109
AV231__00	5400260_1	5400289_1,2	5400287_1	114B095U01	5327445_2	2	1	Omit	Omit
AV231__0N	5400260_1	5400289_1,2	5400287_1	1943573_1	5327445_2	2	1	2	1
AV231__0P	5400260_2	5400289_1,2	5400287_1	114B095U01	5327445_2	2	1	Omit	Omit
AV231__10	5400260_1	5400289_1,2	5400278_1	114B095U01	5327445_1	2	Omit	Omit	Omit
AV231__1N	5400260_1	5400289_1,2	5400278_1	1943573_1	5327445_1	2	Omit	2	1
AV231__1P	5400260_2	5400289_1,2	5400278_1	114B095U01	5327445_1	2	Omit	Omit	Omit
AV231__20	5400260_1	5400289_1,2	5400287_2	114B095U01	Omit	2	Omit	Omit	Omit
AV231__2N	5400260_1	5400289_1,2	5400287_2	1943573_1	Omit	2	Omit	2	1
AV231__2P	5400260_2	5400289_1,2	5400287_2	114B095U01	Omit	2	Omit	Omit	Omit

SUPPORT SERVICES

Table 9-31. Cam and Drive Shaft Parts Reference for
Type AV2 Positioners (Fig. 9-4) (continued)

Type	Item (Part Number)					Item (Quantity)			
	4	13	14	29	63	31 ¹	34	107	109
AV231__30	5400260_1	5400289_1,2	5400287_3	114B095U01	Omit	2	Omit	Omit	Omit
AV231__3N	5400260_1	5400289_1,2	5400287_3	1943573_1	Omit	2	Omit	2	1
AV231__3P	5400260_2	5400289_1,2	5400287_3	114B095U01	Omit	2	Omit	Omit	Omit
AV231__40	5400260_1	5400289_1,2	5400287_4	114B095U01	Omit	2	Omit	Omit	Omit
AV231__4N	5400260_1	5400289_1,2	5400287_4	1943573_1	Omit	2	Omit	2	1
AV231__4P	5400260_2	5400289_1,2	5400287_4	114B095U01	Omit	2	Omit	Omit	Omit
AV231__50	5400260_1	5400289_1,2	5400287_5	114B095U01	Omit	2	Omit	Omit	Omit
AV231__5N	5400260_1	5400289_1,2	5400287_5	1943573_1	Omit	2	Omit	2	1
AV231__5P	5400260_2	5400289_1,2	5400287_5	114B095U01	Omit	2	Omit	Omit	Omit
AV232__00	5400260_1	5400281_1,2	5400287_1	114B095U01	5327445_2	2	1	Omit	Omit
AV232__0N	5400260_1	5400281_1,2	5400287_1	1943573_1	5327445_2	2	1	2	1
AV232__0P	5400260_2	5400281_1,2	5400287_1	114B095U01	5327445_2	2	1	Omit	Omit
AV232__10	5400260_1	5400281_1,2	5400278_1	114B095U01	5327445_1	2	Omit	Omit	Omit
AV232__1N	5400260_1	5400281_1,2	5400278_1	1943573_1	5327445_1	2	Omit	2	1
AV232__1P	5400260_2	5400281_1,2	5400278_1	114B095U01	5327445_1	2	Omit	Omit	Omit
AV232__20	5400260_1	5400281_1,2	5400287_2	114B095U01	Omit	2	Omit	Omit	Omit
AV232__2N	5400260_1	5400281_1,2	5400287_2	1943573_1	Omit	2	Omit	2	1
AV232__2P	5400260_2	5400281_1,2	5400287_2	114B095U01	Omit	2	Omit	Omit	Omit
AV232__30	5400260_1	5400281_1,2	5400287_3	114B095U01	Omit	2	Omit	Omit	Omit
AV232__3N	5400260_1	5400281_1,2	5400287_3	1943573_1	Omit	2	Omit	2	1
AV232__3P	5400260_2	5400281_1,2	5400287_3	114B095U01	Omit	2	Omit	Omit	Omit
AV232__40	5400260_1	5400281_1,2	5400287_4	114B095U01	Omit	2	Omit	Omit	Omit
AV232__4N	5400260_1	5400281_1,2	5400287_4	1943573_1	Omit	2	Omit	2	1
AV232__4P	5400260_2	5400281_1,2	5400287_4	114B095U01	Omit	2	Omit	Omit	Omit
AV232__50	5400260_1	5400281_1,2	5400287_5	114B095U01	Omit	2	Omit	Omit	Omit
AV232__5N	5400260_1	5400281_1,2	5400287_5	1943573_1	Omit	2	Omit	2	1
AV232__5P	5400260_2	5400281_1,2	5400287_5	114B095U01	Omit	2	Omit	Omit	Omit
AV271__000	5400260_1	5400289_1,2	5400287_1	114B095U01	5327445_2	2	1	Omit	Omit
AV271__00N	5400260_1	5400289_1,2	5400287_1	1943573_1	5327445_2	2	1	2	1
AV271__00P	5400260_2	5400289_1,2	5400287_1	114B095U01	5327445_2	2	1	Omit	Omit
AV271__010	5400260_1	5400289_1,2	5400278_1	114B095U01	5327445_1	2	Omit	Omit	Omit
AV271__01N	5400260_1	5400289_1,2	5400278_1	1943573_1	5327445_1	2	Omit	2	1
AV271__01P	5400260_2	5400289_1,2	5400278_1	114B095U01	5327445_1	2	Omit	Omit	Omit
AV271__020	5400260_1	5400289_1,2	5400287_2	114B095U01	Omit	2	Omit	Omit	Omit
AV271__02N	5400260_1	5400289_1,2	5400287_2	1943573_1	Omit	2	Omit	2	1
AV271__02P	5400260_2	5400289_1,2	5400287_2	114B095U01	Omit	2	Omit	Omit	Omit
AV271__030	5400260_1	5400289_1,2	5400287_3	114B095U01	Omit	2	Omit	Omit	Omit
AV271__03N	5400260_1	5400289_1,2	5400287_3	1943573_1	Omit	2	Omit	2	1
AV271__03P	5400260_2	5400289_1,2	5400287_3	114B095U01	Omit	2	Omit	Omit	Omit
AV271__040	5400260_1	5400289_1,2	5400287_4	114B095U01	Omit	2	Omit	Omit	Omit
AV271__04N	5400260_1	5400289_1,2	5400287_4	1943573_1	Omit	2	Omit	2	1
AV271__04P	5400260_2	5400289_1,2	5400287_4	114B095U01	Omit	2	Omit	Omit	Omit

ADDITIONAL SPARE PARTS

Table 9-31. Cam and Drive Shaft Parts Reference for Type AV2 Positioners (Fig. 9-4) (continued)

Type	Item (Part Number)					Item (Quantity)			
	4	13	14	29	63	31 ¹	34	107	109
AV271_050	5400260_1	5400289_1,2	5400287_5	114B095U01	Omit	2	Omit	Omit	Omit
AV271_05N	5400260_1	5400289_1,2	5400287_5	1943573_1	Omit	2	Omit	2	1
AV271_05P	5400260_2	5400289_1,2	5400287_5	114B095U01	Omit	2	Omit	Omit	Omit
AV272_000	5400260_1	5400281_1,2	5400287_1	114B095U01	5327445_2	2	1	Omit	Omit
AV272_00N	5400260_1	5400281_1,2	5400287_1	1943573_1	5327445_2	2	1	2	1
AV272_00P	5400260_2	5400281_1,2	5400287_1	114B095U01	5327445_2	2	1	Omit	Omit
AV272_010	5400260_1	5400281_1,2	5400278_1	114B095U01	5327445_1	2	Omit	Omit	Omit
AV272_01N	5400260_1	5400281_1,2	5400278_1	1943573_1	5327445_1	2	Omit	2	1
AV272_01P	5400260_2	5400281_1,2	5400278_1	114B095U01	5327445_1	2	Omit	Omit	Omit
AV272_020	5400260_1	5400281_1,2	5400287_2	114B095U01	Omit	2	Omit	Omit	Omit
AV272_02N	5400260_1	5400281_1,2	5400287_2	1943573_1	Omit	2	Omit	2	1
AV272_02P	5400260_2	5400281_1,2	5400287_2	114B095U01	Omit	2	Omit	Omit	Omit
AV272_030	5400260_1	5400281_1,2	5400287_3	114B095U01	Omit	2	Omit	Omit	Omit
AV272_03N	5400260_1	5400281_1,2	5400287_3	1943573_1	Omit	2	Omit	2	1
AV272_03P	5400260_2	5400281_1,2	5400287_3	114B095U01	Omit	2	Omit	Omit	Omit
AV272_040	5400260_1	5400281_1,2	5400287_4	114B095U01	Omit	2	Omit	Omit	Omit
AV272_04N	5400260_1	5400281_1,2	5400287_4	1943573_1	Omit	2	Omit	2	1
AV272_04P	5400260_2	5400281_1,2	5400287_4	114B095U01	Omit	2	Omit	Omit	Omit
AV272_050	5400260_1	5400281_1,2	5400287_5	114B095U01	Omit	2	Omit	Omit	Omit
AV272_05N	5400260_1	5400281_1,2	5400287_5	1943573_1	Omit	2	Omit	2	1
AV272_05P	5400260_2	5400281_1,2	5400287_5	114B095U01	Omit	2	Omit	Omit	Omit

NOTE:

1. Item quantity differs for Type AV2 positioners with the shaft position transmitter option. Refer to Table 9-33 for the quantity.

Table 9-32. Manifold/Gage Block Parts Reference for Type AV2 Positioners (Fig. 9-4)

Type	Item (Part Number)	Item (Quantity)				
	17	64	65	66	67	105, 106
AV23_0_	Omit	Omit	Omit	Omit	Omit	Omit
AV23_1_	5400282_1	4	4	2	2	Omit
AV23_2_	5400282_2	4	4	2	2	Omit
AV23_3_	5400318_1	4	3	3	Omit	3
AV27_00_	Omit	Omit	Omit	Omit	Omit	Omit
AV27_10_	5400282_1	4	4	2	2	Omit
AV23_20_	5400282_2	4	4	2	2	Omit
AV23_30_	5400318_1	4	3	3	Omit	3

Table 9-33. Shaft Position Transmitter Parts Reference for Type AV2 Positioners (Fig. 9-4)

Type	Item (Part No.)	Item (Quantity)					
	21	27, 95,96, 103	31	63	91, 101	92, 104	102
AV23__0__	Omit	Omit	2	Refer to Table 9-31	Omit	Omit	Omit
AV23__1__	6639540_2	1	3+1	Omit	Omit	2	Omit
AV23__2__	6639540_1	1	3+1	Omit	1	2	2

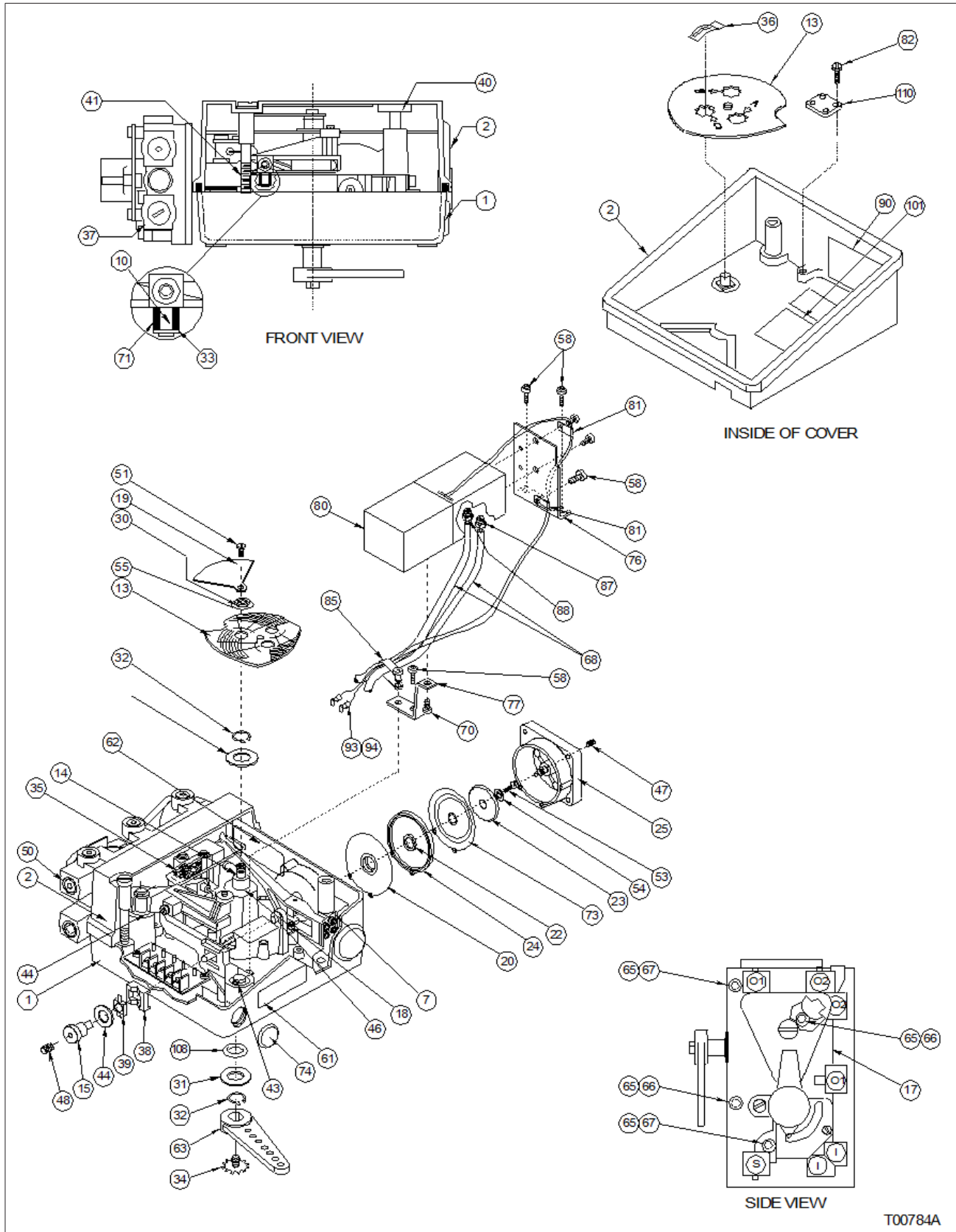

Figure 9-4. Type AV2 Positioner (Page 1 of 2)

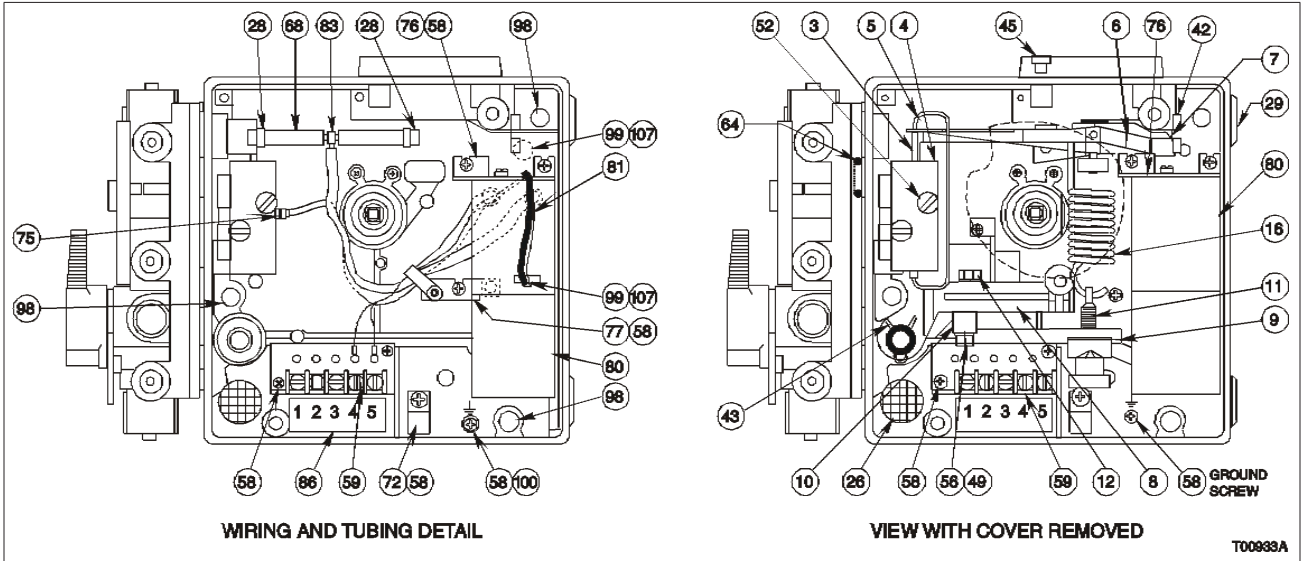

Figure 9-5. Type AV2 Positioner (Page 2 of 2)

Table 9-34. Conversion Kits

Part No.	Qty	Application	Description
258651_1	1	AV23	I/P Conversion Kit ¹

NOTE:

1. Replaces older I/Ps that required an internal 22 psi pressure pre-regulator.

APPENDIX A - POSITION TRANSMITTERS

INTRODUCTION

This appendix provides operation and calibration information for ABB position transmitter options. Refer to Table 1-4 (potentiometric position transmitter) or Table 1-5 (four to 20-milliamp position transmitter) for position transmitter performance specifications. A position transmitter provides additional control features to Type AV positioners and can be ordered through nomenclature.

Position transmitters sense the position of the positioner cam shaft. Two variations exist:

- Potentiometric option (AV____1__).
- 4 to 20-milliamp option (AV____2__).

DESCRIPTION AND OPERATION

Position transmitters are available as options (order through nomenclature).

The Type AV____1__ potentiometric position transmitter option uses a high durability plastic film potentiometer. Gears connect the potentiometer to the positioner cam shaft. The position of the potentiometer shaft indicates the position of the actuator.

The relationship between the potentiometer and the cam shaft results in one degree of rotation of the cam shaft corresponding to approximately 9.9 ohms of resistive change at the potentiometer wiper. Three leads from the potentiometer are for customer use and are available at terminals TB1-1, TB1-2 and TB1-3.

The Type AV____2__ four to 20-milliamp position transmitter option also uses a high durability plastic film potentiometer and electronic circuitry. Gears connect the potentiometer shaft to the positioner cam shaft. The resistive change of the potentiometer outputs to a bridge circuit, producing a proportional voltage. EMI/RFI protected circuitry converts the bridge voltage to a four to 20-milliamp current signal. Terminals TB1-1 (+) and TB1-2 (-) of the Type AV positioner provide customer access to the four to 20-milliamp control signal. Jumper position determines direct or reverse acting operation. Test jacks are available for in-line current monitoring.

CALIBRATION

There are two procedures for calibration; one for the potentiometric option (Type AV____1__) and another for the four to 20-milliamp option (Type AV____2__).

Calibrating the Potentiometric Position Transmitter

This calibration example using the potentiometric position transmitter can be used as a guide for other applications. Final calibration of the potentiometric position transmitter option depends on the application. Field connections to the potentiometer are shown on a label located inside the positioner cover. The label is shown in Figure A-1.

NOMENCLATURE	TB1 CONNECTIONS				
	1	2	3	4	5
AV23?????				+	-
AV33?????				+	-
AV44?????	+	-	+24	RAISE	LOWER
AV????1??					
AV????2??	+	-			

T00807A

Figure A-1. Terminal Block Connections

The nomenclature and terminal connections of Figure A-1 are:

- AV23** The positive (+) and negative (-) connections at position TB1-4 and TB1-5 refer to the four to 20-milliamp signal to the I/P converter.

- AV33** Not applicable.

- AV44** Not applicable.

- AV ____ 1 __** Depicts the connections for the potentiometric position transmitter option.

- AV ____ 2 __** The positive (+) and negative (-) connections at position TB1-1 and TB1-2 refer to the output signal from the four to 20-milliamp position transmitter.

Direct acting cam rotation of zero to 100 percent produces increasing resistance between terminal block TB1-1 and TB1-2. Reverse acting cam rotation of zero to 100 percent produces decreasing resistance between TB1-1 and TB1-2.

The resistive change of the potentiometer is approximately 9.9 ohms (nominal) per degree of cam rotation, with a total resistance of 2000 ohms (nominal).

Application of the potentiometric option must consider the possibility of end resistance wrap-around.

POTENTIOMETRIC APPLICATION EXAMPLE

A customer has a Type AV positioner with a 90-degree, direct acting cam, potentiometric position transmitter, along with a 24-VDC supply. The customer wishes to output a five-VDC signal when the Type AV positioner output is 80 percent.

1. Determine the angular rotation of 80% of 90°.

$$0.80 \times 90^\circ = 72^\circ$$

72° of cam rotation is 80% of 90°.

2. Determine the resistive change of the potentiometer through 72° of rotation. For every degree of rotation the resistive change is 9.9Ω (nominally):

$$72^\circ \times 9.9 \Omega = 712.8 \Omega$$

The change of resistance for this rotation is 712.8 Ω, and appears between TB1-1 and TB1-2.

3. To guard against **wrap-around**, the minimum resistance at the potentiometer wiper at zero percent cam rotation is set to 200 Ω. Therefore, the resistance between TB1-1 and TB1-2 should vary between 200 and 912.8 (712.8 + 200 = 912.8) Ω for a cam rotation of zero to 80%.

4. Determine the required current in the potentiometer that develops 5 VDC at the wiper at 80%:

$$5 \text{ VDC} \div 912.8 \Omega = 5.48 \text{ mA}$$

5. Determine the nominal voltage to produce 5.48 mA across the potentiometer:

$$5.48 \text{ mA} \times 2000 \Omega = 10.96 \text{ VDC}$$

6. Determine the dropping resistor value that reduces the supply voltage to 10.96 VDC:

$$\frac{(24.00 - 10.96) \text{ VDC}}{5.48 \text{ mA}} = 2380 \Omega$$

Connect a 2380-ohm variable resistor in series with the power supply. A variable resistor is required to account for the 20-percent

tolerance of the potentiometer. Figure A-2 is a schematic diagram of this application example.

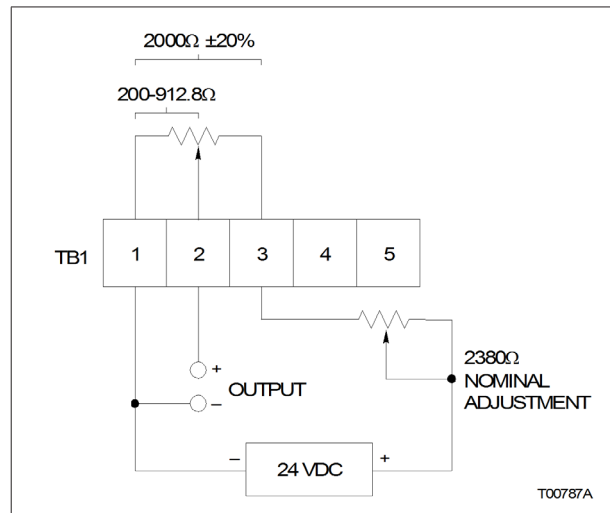

Figure A-2. Schematic Diagram

CALIBRATING THE POTENTIOMETRIC EXAMPLE

The calibration information is based on the application put forth in **POTENTIOMETRIC APPLICATION EXAMPLE**.

1. Move the actuator to the 0% output position.
2. Remove the field wiring from TB1-1, TB1-2 and TB1-3. Using an ohmmeter, measure the resistance between TB1-1 and TB1-2. If the reading is $200, \pm 20 \Omega$, remove the ohmmeter and proceed to Step 3. Otherwise continue with Step 2.

WARNING

The pneumatic supply pressure must be turned off before removing the positioning cam. The final control element will go to one end of the stroke and can cause a process upset. Some process upsets may cause damage to equipment and endanger personnel.

- a. Remove the cam by removing the screw, flag, nut and washer (Fig. A-3 and Table A-1).
- b. Loosen the set screw on the hub of the small gear using a $\frac{1}{16}$ -in. Allen wrench (Fig. A-3 and Table A-1).
- c. Use a screwdriver to adjust the shaft on the potentiometer until the ohmmeter reads $200, \pm 20 \Omega$. While adjusting the resistance, hold the gears and cam shaft stationary so rotation does not occur. Only the potentiometer shaft should move while adjusting the resistance.

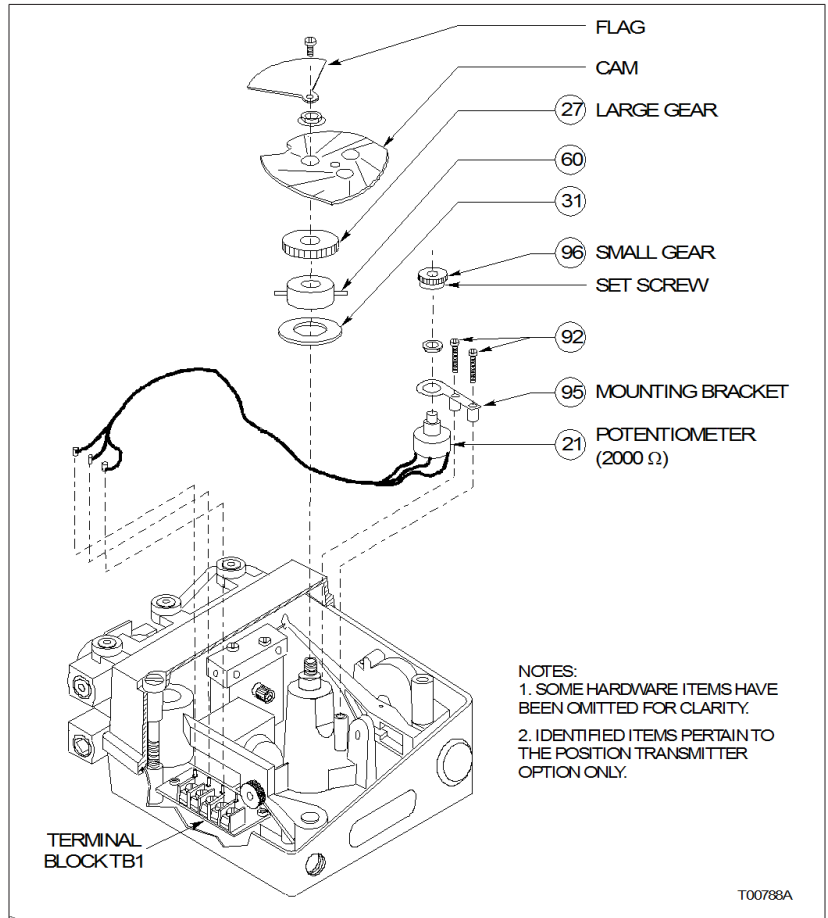

Figure A-3. Potentiometric Position Transmitter (Exploded View)

Table A-1. Potentiometric Position Transmitter Kit 258670_1

Item No.	Part No.	Qty	Description
21	6639540_2	1	Potentiometer assembly
27	193243_1	1	Large position transmitter gear
31	19734_45	1	Washer
60	5400317_1	1	Gear adapter
92	NDPAC13012	2	Threaded forming screw
95	5400268_1	1	Potentiometer mounting bracket
96	193242_1	1	Small position transmitter gear

d. Tighten the set screw on the small gear hub.

NOTE: If the mesh between the large and small gears is not tight, adjust the position of the potentiometer mounting bracket (Fig. A-3 and Table A-1) so that backlash is eliminated.

e. Remove the ohmmeter from TB1-1 and TB1-2. Install the cam, screw, flag, nut and washer (Fig. A-3 and Table A-1).

3. Connect the field wiring to the terminal block. Connect a DC voltmeter between TB1-1 (-) and TB1-2 (+).
4. Move the actuator to the 80% position. Adjust the resistor in series with the 24-VDC supply until the voltmeter reads five VDC.
5. Move the actuator to the 0% position to verify that the voltmeter reads less than five VDC.
6. Move the actuator to the 100% position to verify that the voltmeter reads greater than five VDC.

Calibrating the 4 to 20-mA Position Transmitter

Labels located inside the positioner cover show the location of jumpers, test points, calibration potentiometers and field connection terminals for the position transmitter (Figs. A-1 and A-4).

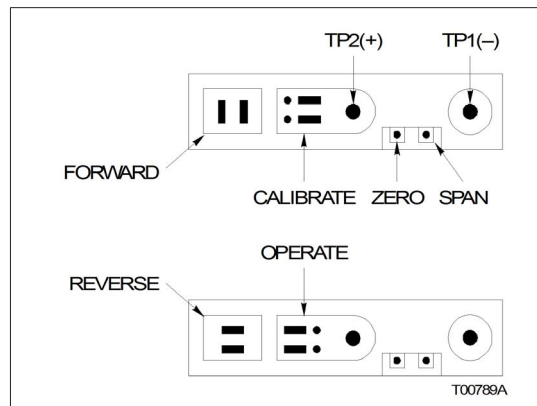

Figure A-4. Calibration Features for 4 to 20-mA Position Transmitter

1. Remove the FOR/REV jumpers, and place the CAL/OPER jumpers in the calibrate (CAL) position (Fig. A-4).
2. Move the actuator to the 50% output position.
3. Insert ohmmeter leads into test jacks TP1 (-) and TP2 (+). If the resistance value is between 940 and 1060 Ω , remove the ohmmeter leads and proceed to Step 4. Otherwise continue with Step 3.

WARNING

The pneumatic supply pressure must be turned off before removing the positioning cam. The final control element will go to one end of the stroke and can cause a process upset. Some process upsets may cause damage to equipment and endanger personnel.

a. Remove the cam, by removing the screw, flag, nut and washer (Fig. A-5 and Table A-2).

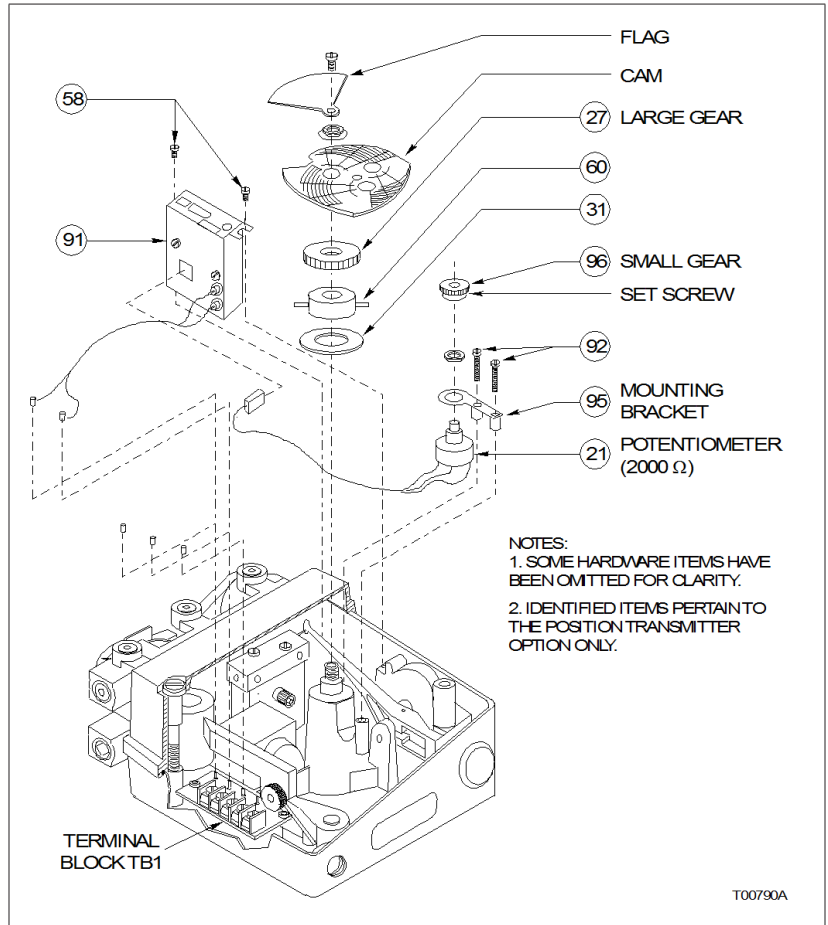

Figure A-5. 4 to 20-mA Position Transmitter (Exploded View)

Table A-2. 4 to 20-mA Position Transmitter Kit 258670_1

Item No.	Part No.	Qty	Description
21	6639540_1	1	Potentiometer assembly
27	193243_1	1	Large position transmitter gear
31	19734_45	1	Washer
58	NDPAC13005	2	Threaded forming screw
60	5400317_1	1	Gear adapter
91	6639479_1	1	4 to 20 mA position transmitter assembly
92	NDPAC13012	2	Threaded forming screw
95	5400268_1	1	Potentiometer mounting bracket
96	193242_1	1	Small position transmitter gear

b. Loosen the set screw on the hub of the small gear using a $\frac{1}{16}$ -in. Allen wrench (Fig. A-5 and Table A-2).

c. Use a screwdriver to adjust the shaft on the potentiometer until the ohmmeter reads 1000, $\pm 10 \Omega$. While adjusting the resistance, hold the gears and cam shaft stationary so rotation does not occur. Only the potentiometer shaft should move while adjusting the resistance.

NOTE: If the mesh between the large and small gears is not tight, adjust the position of the potentiometer mounting bracket (Fig. A-5 and Table A-2) so that backlash is eliminated.

d. Tighten the set screw on the small gear hub.

e. Remove the ohmmeter from TB1-1 and TB1-2. Install the cam, screw, flag, nut and washer (Fig. A-5 and Table A-2).

4. Place the CAL/OPER jumpers into the operate (OPER) position (Fig. A-4). If a direct acting cam is being used, place the FOR/REV jumpers in the FOR position. For a reverse acting cam, place these jumpers in the REV position (Fig. A-4).

5. Connect a 24-VDC external power supply across TB1-1 and TB1-2.

6. Move the actuator to the 0% position. Insert ammeter leads into TP2(+) and TP1(-). If the position of the cam limits access to TP1, connect the (-) lead to TB1-2 on the terminal block.

7. Adjust the zero potentiometer to 4.00 mA. Refer to Figure A-4 for the location of the zero potentiometer.

8. Move the actuator to the 100% position. Adjust the span potentiometer to 20.00 mA. Refer to Figure A-4 for the location of the span potentiometer.

9. Repeat Steps 7 and 8 until the indicated current readings are obtained.

APPENDIX B - QUICK START

INTRODUCTION

This section is intended for control engineers with in-depth knowledge of positioners and positioner applications. This quick start only highlights the primary tasks involved in installation and operation. **Section 1** through **Section 5**, in the main body of this instruction address installation and operation in more detail.

PRODUCT IDENTIFICATION (NOMENCLATURE)

Table B-1. Nomenclature

Position	1	2	3	4	5	6	7	8	9	
Type	A	V	-	-	-	-	-	-	-	Characterizable Positioners
	1									Characterizable Pneumatic Positioner
	2									Characterizable 4 to 20-mA Input Positioner (actuator moves to 0% or 100% upon loss of signal)
										Input Signal
		1								20.7 to 103.4 kPa (3.0 to 15.0 psig) (Type AV1)
		2								20.7 to 186.2 kPa (3.0 to 27.0 psig) (Type AV1)
		3								4 to 20 mA (standard intrinsically safe Type AV2)
		5								20.7 to 103.4 kPa (3.0 to 15.0 psig), high temperature applications (Type AV1) ¹
		6								20.7 to 186.2 kPa (3.0 to 27.0 psig), high temperature applications (Type AV1) ¹
		7								4 to 20 mA with explosionproof I/P converter (NEMA 7) (Type AV2) ²
										Stroke/Rotary Motion (cam selection)
		1								12.7 to 50.8 mm (0.5 to 20.0 in.) or 45° rotary motion
		2								25.4 to 101.6 mm (1.0 to 4.0 in.) or 90° rotary motion
										Manifold (includes filters)/ Gage Block
					0					No manifold
					1					Manifold with equalizing valve, filters and gage ports (required for double acting actuators with manual override)
					2					Manifold with equalizing valve inoperable (includes filters and gage ports) ³
					3					Gage block (gage port only) ¹
										Position Transmitter
						0				None (must be 0 for Types AV15, AV16 and AV27)
						1				Potentiometric resistive output
						2				4 to 20-mA output

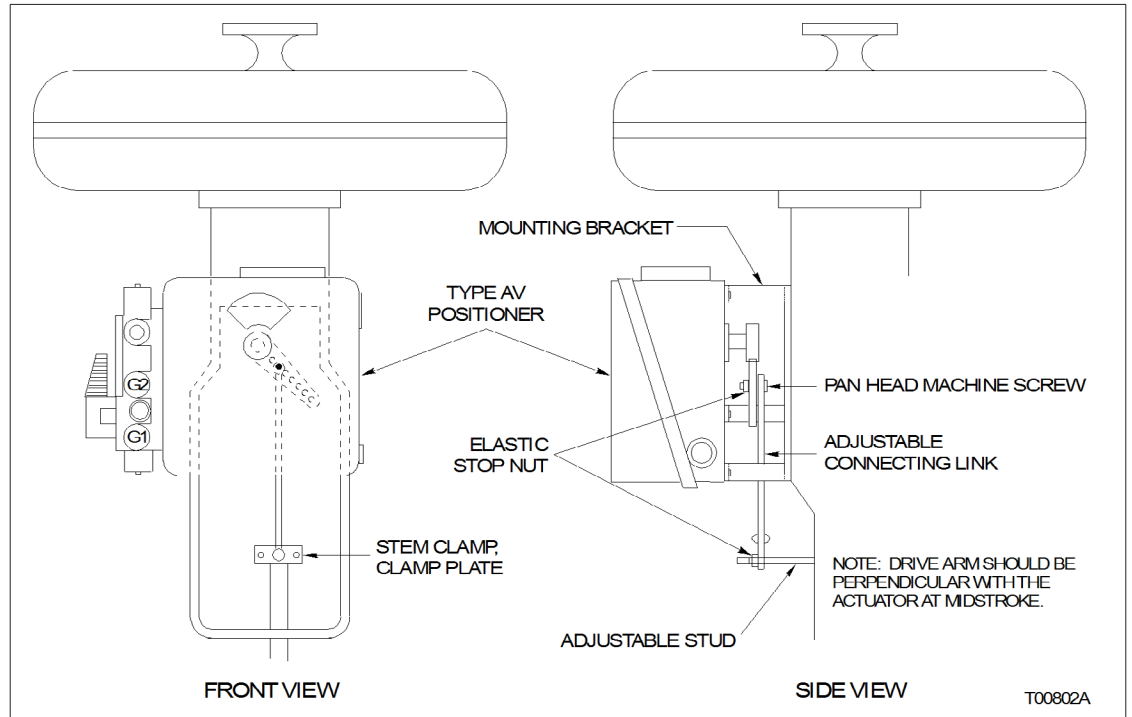

Figure B-1. Mounting Using Linkage (Typical)

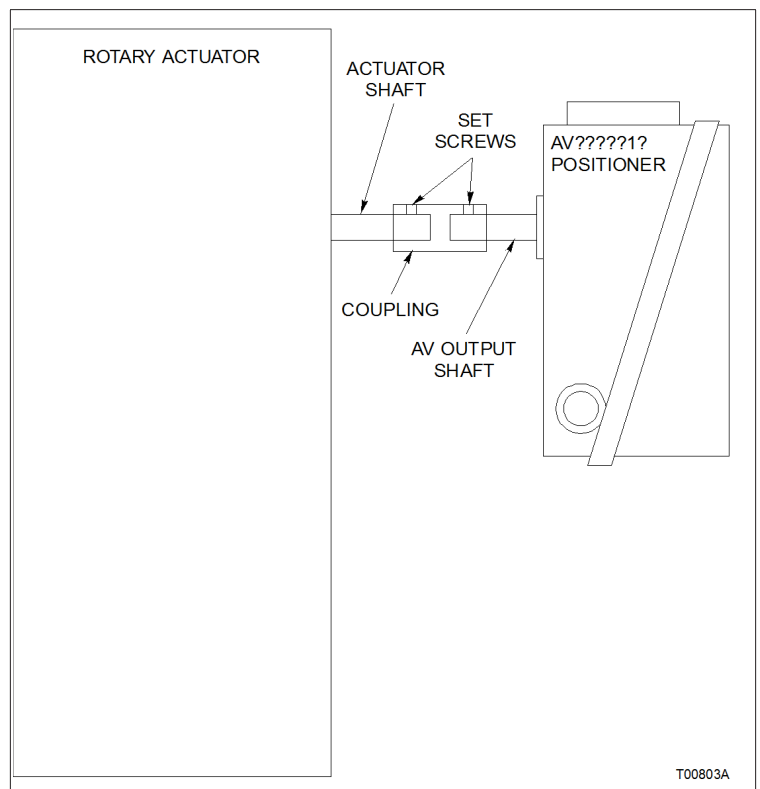

Figure B-2. Mounting Using Direct Coupling (Typical)

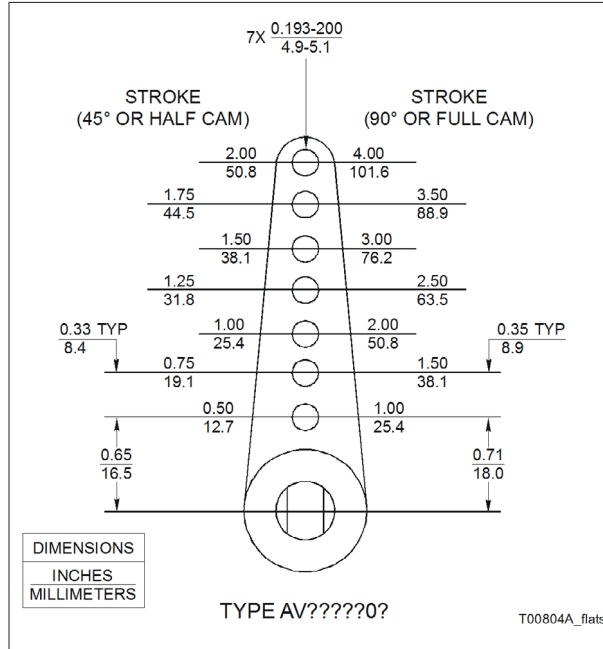

Figure B-3. Drive Arm Connections

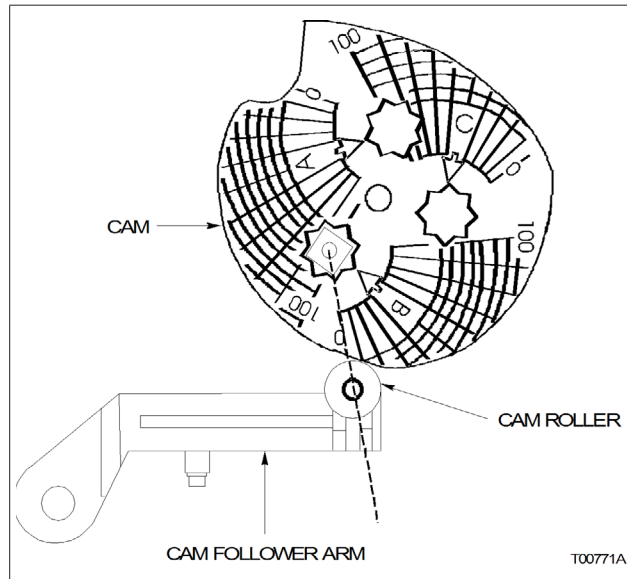

Figure B-4. Cam Roller Alignment

TUBING CONNECTIONS

1. Connect the required supply air to connection S (Fig. B-5).

NOTE: Maximum torque for ¼-NPT fittings is 13.6 Nm (10.0 ft-lbs).

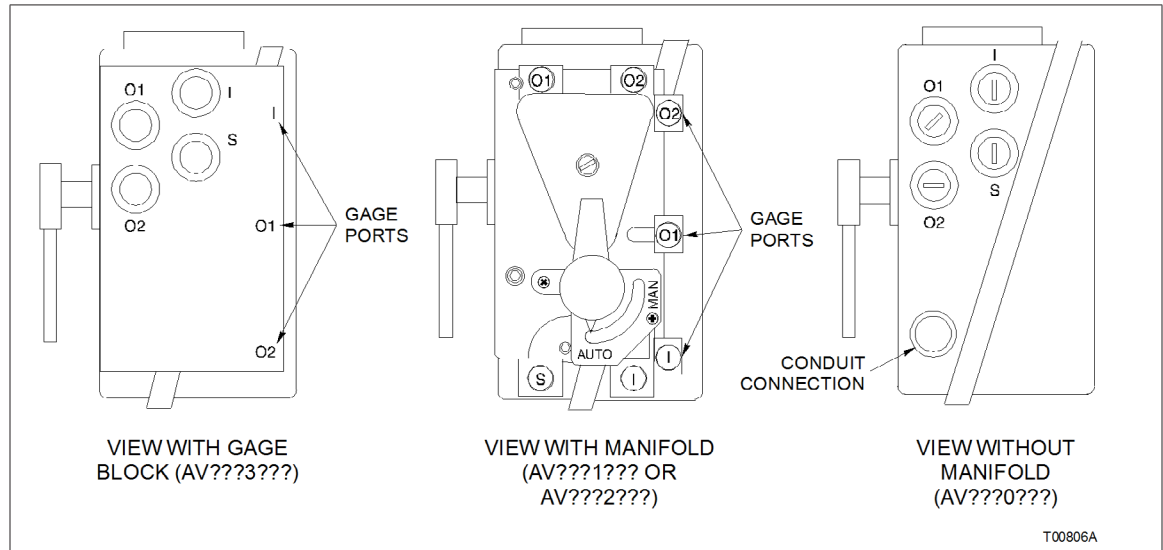

Figure B-5. Port Locations

2. Based on the positioner type, perform one of the following steps (Fig. B-5):

- **AV11 and AV15:** Connect 20.7 to 103.4-kPa (3.0 to 15.0-psig) instrument signal to connection I.
- **AV12 and AV16:** Connect 20.7 to 186.2-kPa (3.0 to 27.0-psig) instrument signal to connection I.
- **AV2:** Connection I is not used and should be plugged. If it is not plugged, do so at this time.

NOTE: Use liquid or paste pipe sealant to seal the connection. Maximum torque for ¼-NPT fittings is 13.6 Nm (10.0 ft-lbs).

3. Connect the output ports O1 and O2 as required to provide the desired direction of rotation. Figures B-6, B-7, B-8 and B-9 show a single acting tubing example, and Figure B-10 shows a double acting tubing example.

NOTE: The piping arrangements shown in Figures B-6, B-7, B-8, B-9 and B-10 are general examples and may not reflect the arrangement required for the application.

4. Install ¼-NPT permanent instrument gages to the gage ports if desired or for calibration requirements.

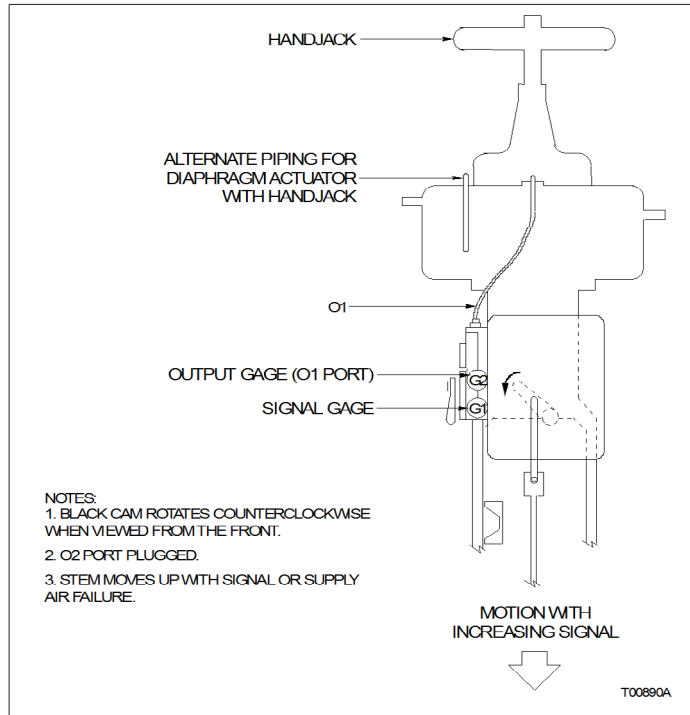

Figure B-6. Direct Acting, Top Loaded, Single Acting Tubing Example

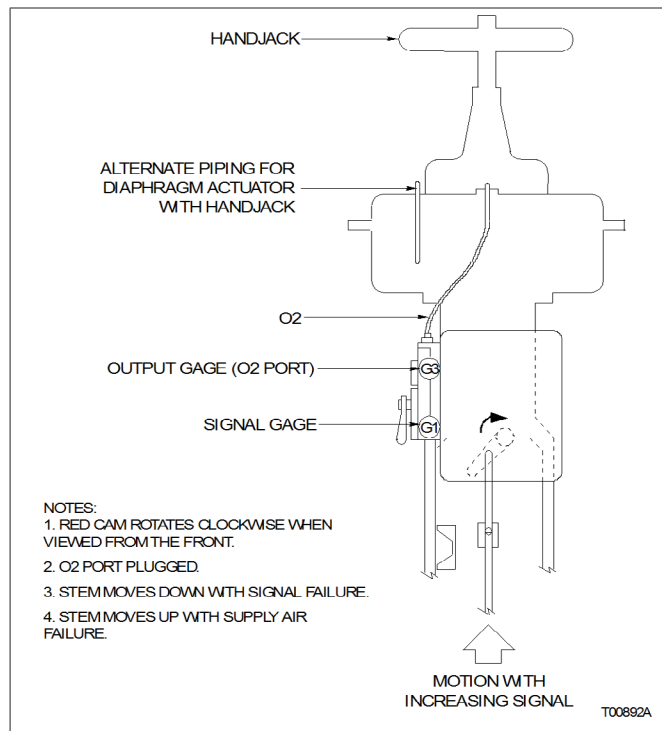

Figure B-7. Reverse Acting, Top Loaded, Single Acting Tubing Example

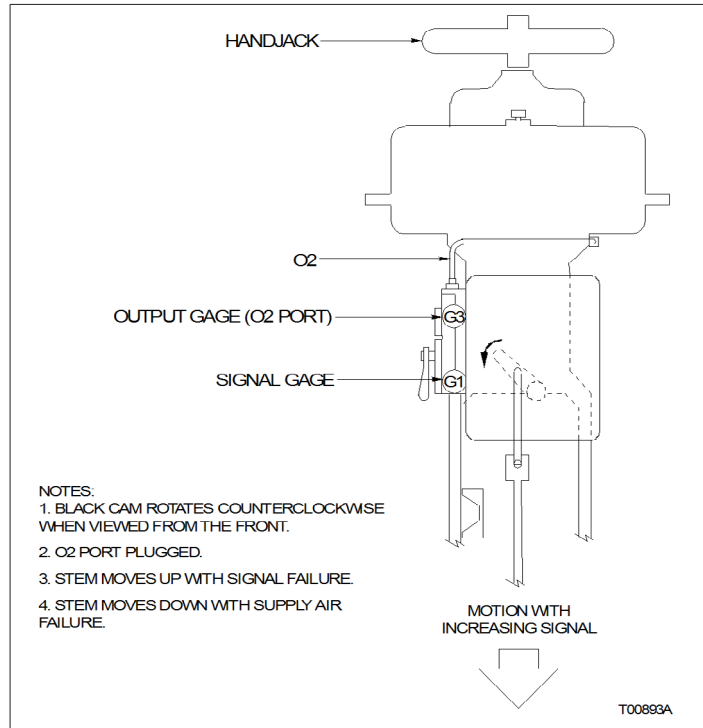

Figure B-8. Direct Acting, Bottom Loaded, Single Acting Tubing Example

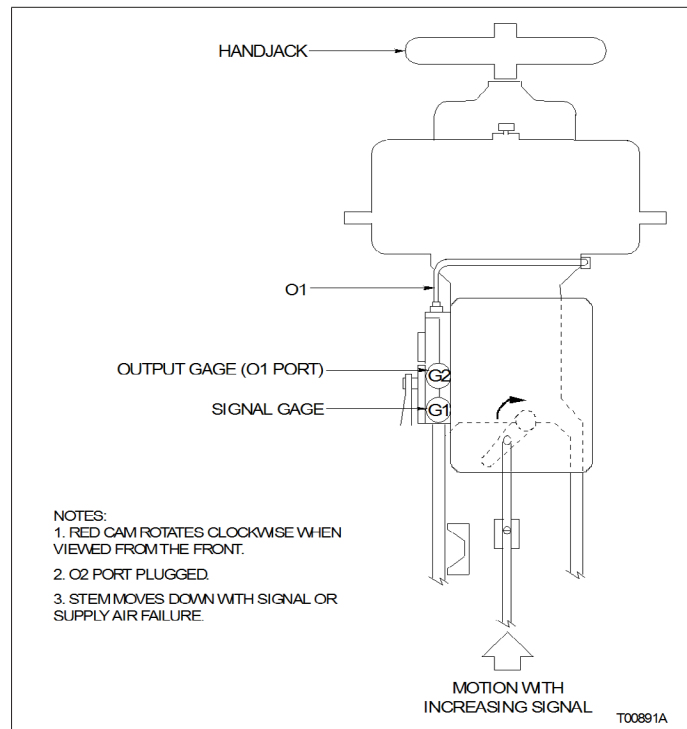

Figure B-9. Reverse Acting, Bottom Loaded, Single Acting Tubing Example

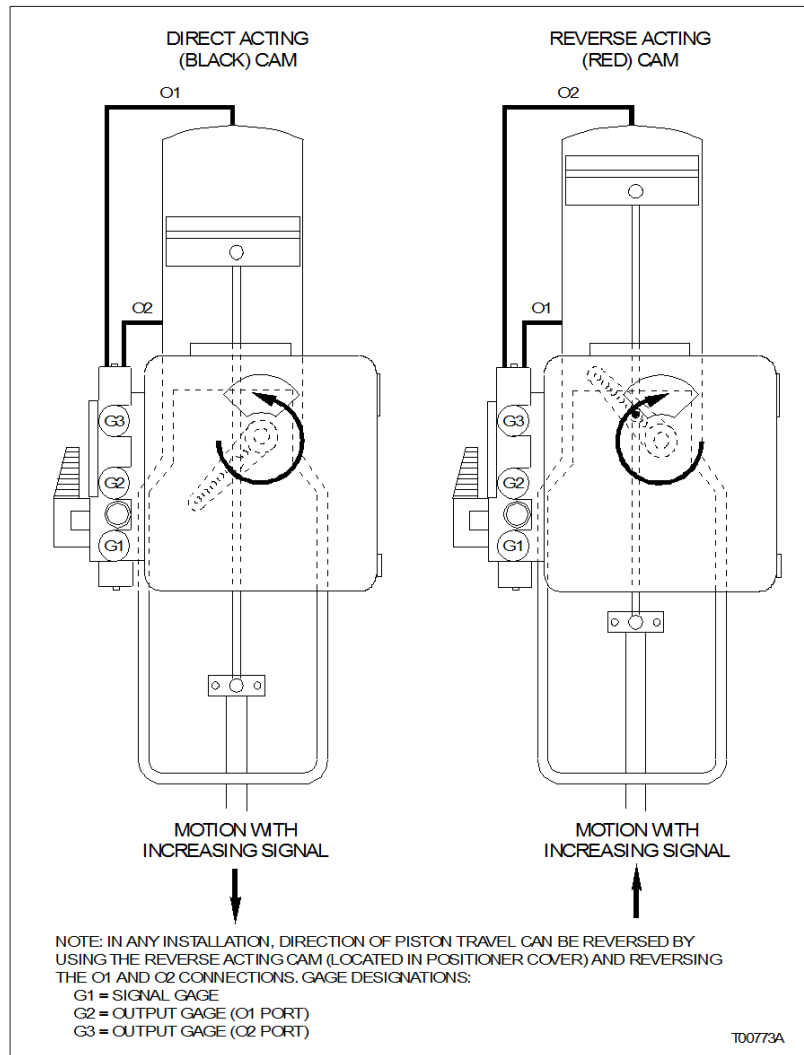

Figure B-10. Double Acting Tubing Example

TYPE AV2 POSITIONER WIRING

This section covers the wiring connections for Type AV2 positioner:

1. Connect the four to 20-mA position demand signal wires to terminals TB1-4 (+) and TB1-5 (-) of the terminal block (Fig. B-11). If you have a Type AV2__0__ positioner, go to Step 4.

NOTE: If using a twisted shielded pair for signal wiring, ground one end of the shielded pair at the source. Trim the other end of the pair, located inside the enclosure, so that bare wires are not exposed.

2. If equipped with an optional 4 to 20-mA position transmitter (AV2__2__), connect a 24-VDC power supply in series with the required output load (Table 1-5) to terminals TB1-1 (+) and TB1-2 (-).

NOMENCLATURE	TB1 CONNECTIONS				
	1	2	3	4	5
AV23?????				+	-
AV33?????				+	-
AV44?????	+	-	+24	RAISE	LOWER
AV????1??					
AV????2??	+	-			

T00807A

Figure B-11. Wiring Connections

3. If equipped with optional potentiometric position transmitter (AV2__1__), connect a power supply (maximum 35 VDC or 30 VAC) across TB1-1 and TB1-3. Use the signal across TB1-1 and TB1-2 or TB1-2 and TB1-3 for position transmitter feedback. Refer to [Appendix A](#) for detailed information about position transmitters.

NOTE: Route the wiring inside the positioner so it does not become entangled with moving parts. A cable clamp (Figure B-12) is provided inside the positioner so entanglement can be avoided.

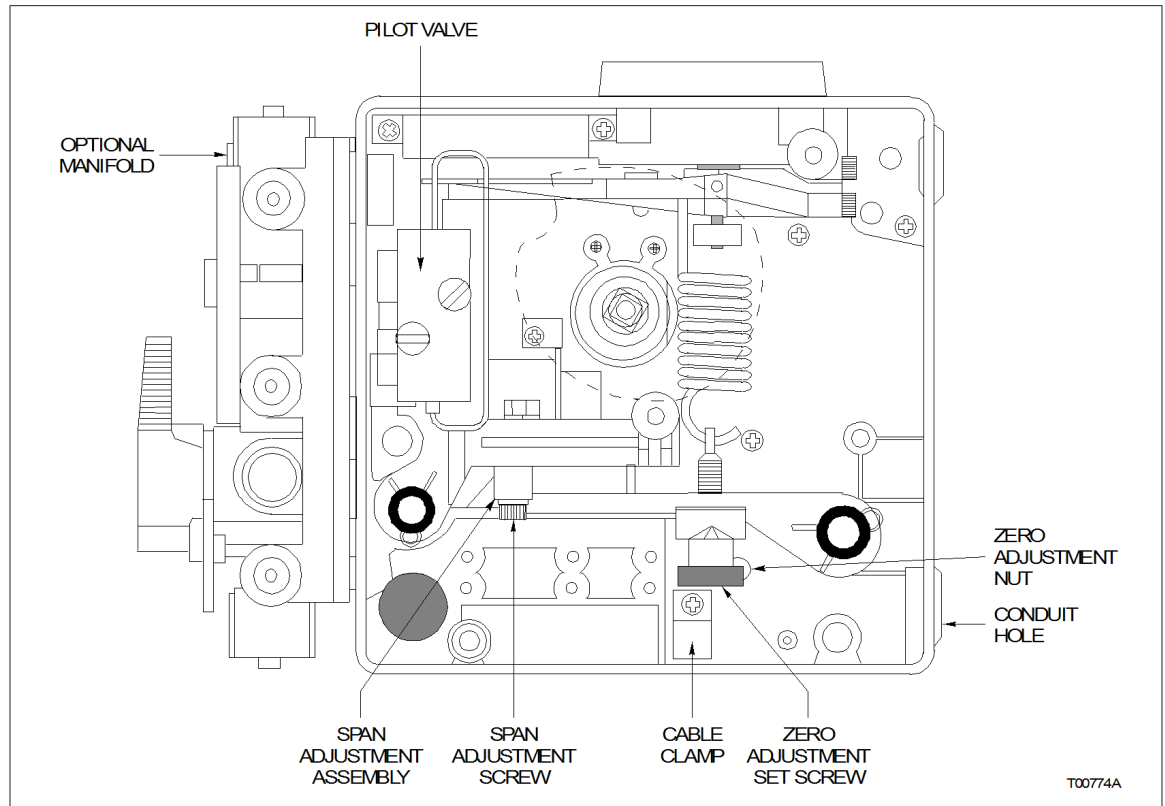

Figure B-12. Calibration Adjustments

4. Grounding positioners should be done in accordance with local electrical codes (in U.S, National Electrical Code, ANSI/NFPA 70. In Canada, Canadian Electrical Code, CSA c22.1). A grounding screw is provided inside the AV enclosure for grounding, denoted by .

NOTES:

1. The grounding screw located inside the AV enclosure is a safety ground and should not be used to ground the shielded pair.
2. The positioner must be grounded to avoid ground loop conditions.

TYPE AV1 POSITIONER WIRING

This section applies to the following positioners:

- Type AV1__1__.
- Type AV1__2__.

NOTES:

1. For a Type AV1__0__ positioner, no electrical wiring is required.
 2. If using a twisted shielded pair for signal wiring, ground one end of the shielded pair at the source. Trim the other end of the pair, located inside the enclosure, so that bare wires are not exposed.
1. If equipped with optional 4 to 20-mA position transmitter (Type AV1__2__), connect a 24-VDC power supply in series with the required output load (Table 1-5) to terminals TB1-1 (+) and TB1-2 (-) (Fig. B-11). Refer to [Appendix A](#) for detailed information about position transmitters.
 2. If equipped with optional potentiometric position transmitter (Type AV1__2__), connect a power supply (maximum 35 VDC or 30 VAC) across TB1-1 and TB1-3. Use the signal across TB1-1 and TB1-2 or TB1-2 and TB1-3 for position transmitter feedback. Refer to [Appendix A](#) for detailed information about position transmitters.

NOTE: Route the wiring inside the positioner so it does not become entangled with moving parts. A cable clamp (Fig. B-12) is provided inside the positioner so entanglement can be avoided.

3. Grounding positioners should be done in accordance with local electrical codes (in U.S, National Electrical Code, ANSI/NFPA 70. In Canada, Canadian Electrical Code, CSA c22.1). A grounding screw is provided inside the AV enclosure for grounding, denoted by .

NOTES:

1. The grounding screw located inside the AV enclosure is a safety ground and should not be used to ground the shielded pair.
2. The positioner must be grounded to avoid ground loop conditions.

CALIBRATION

Table B-2 presents calibration procedures for Type AV1 and Type AV2 positioners in table format.

Table B-2. Calibration Procedures

AV1		AV2	
Adj	Procedure	Adj	Procedure
Zero	1. Apply 20.7 kPa (3.0 psig) input signal pressure to the positioner. The actuator should be in the closed position.	Zero	1. Turn on supply air. Apply a 4-mA input signal to the positioner. The actuator should be in the closed position.
	2. To adjust the zero, loosen the zero adjustment setscrew (Fig. B-12) using a $\frac{3}{32}$ -inch Allen wrench.		2. To adjust the zero, loosen the zero adjustment setscrew (Fig. B-12) using a $\frac{3}{32}$ -inch Allen wrench.
	3. Turn the zero adjustment nut (clockwise moves actuator toward minimum span) until the 0 radial line on the cam intersects with the center of the cam roller (Fig. B-4).		3. Turn the zero adjustment nut (clockwise moves actuator toward minimum span) until the 0 radial line on the cam intersects with the center of the cam roller (Fig. B-4).
	4. Tighten the zero adjustment setscrew.		4. Tighten the zero adjustment setscrew.
Span	1. Apply the following input signal pressures, depending on the nomenclature type: Types AV11 and AV15: 103.4 kPa (15.0 psig). Actuator should move to its full open position. Types AV12 and AV16: 186.2 kPa (27.0 psig). Actuator should move to its full open position.	Span	1. Apply a 20-mA signal to the positioner. The actuator should be in its full open position.
	2. To adjust the span, loosen the span adjustment screw (Fig. B-12) using a $\frac{3}{32}$ -inch Allen wrench.		2. To adjust the span, loosen the span adjustment screw (Fig. B-12) using a $\frac{3}{32}$ -inch Allen wrench.
	3. Slide span adjustment assembly (Fig. B-12) until the actuator moves to align the 100% radial line with the center of the cam roller (toward pilot valve increases span).		3. Slide span adjustment assembly (Fig. B-12) until the actuator moves to align the 100% radial line with the center of the cam roller (toward pilot valve increases span).
	4. Tighten the span adjustment screw.		4. Tighten the span adjustment screw.

APPENDIX C - CAM CHARACTERIZATION

INTRODUCTION

This section provides cam shaping information. Cam shaping is the process of changing the shape of the cam by cutting or forming so the control signal produces the desired control characteristic. The standard cam normally does not require shaping.

CAM CHARACTERIZATION

Selecting or shaping these cams allows you to obtain a piston (or valve) position versus control signal characteristic that will produce a desired controlled medium versus control signal characteristic. An example is a desired flow rate of air, water or steam through a valve for each control signal pressure applied to the positioner.

The control characteristics for which the cams are shaped are listed in Table 3-1 and are shown in Figures C-1, C-2 and C-3. The figures show a family of curves for each cam whose boundaries are established by a span adjustment.

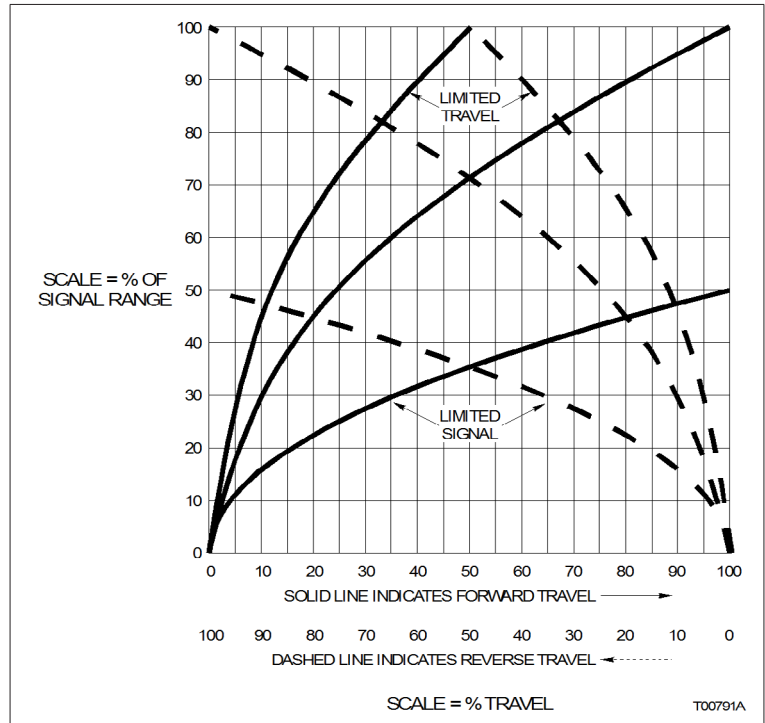

Figure C-1. Cam A, Square Root Relationship

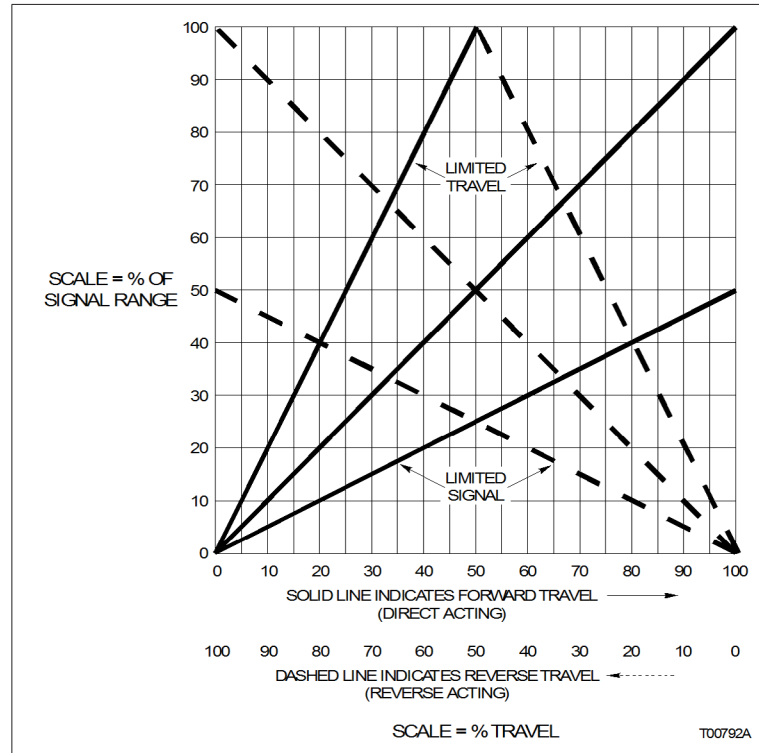

Figure C-2. Cam B, Linear Relationship

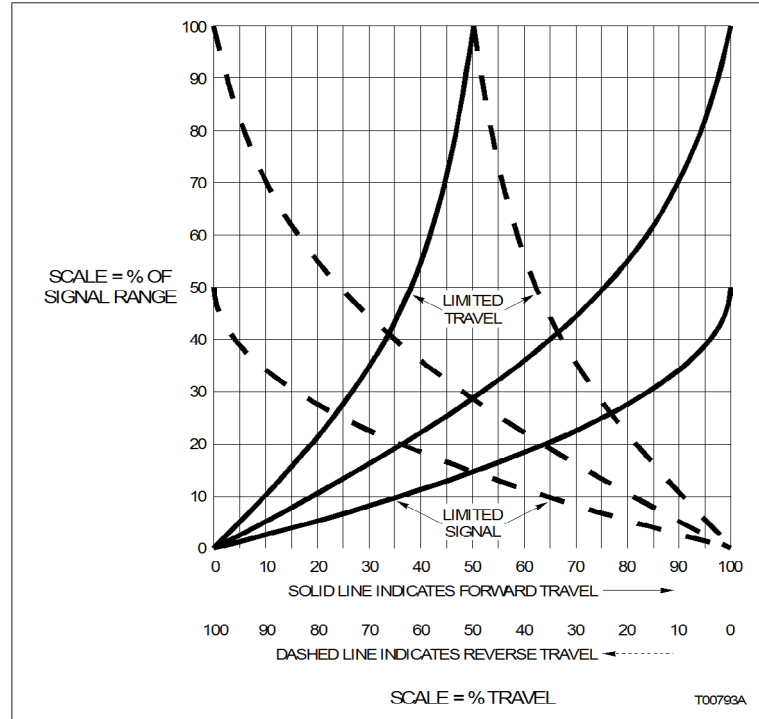

Figure C-3. Cam C, Square Relationship

Table C-1 relates the percentage of control signal to the corresponding pressure values of the input signal. Table C-2 relates the percentage of control signal to input (current) and output (pounds per square inch gage) values of the I/P converter.

Table C-1. Control Signal Pressure Conversions (AV1)

% of Control Signal	Control System Spans				% of Control Signal	Control System Spans			
	20.7 to 103.4 kPa (3.0 to 15.0 psig)		20.7 to 186.2 kPa (3.0 to 27.0 psig)			20.7 to 103.4 kPa (3.0 to 15.0 psig)		20.7 to 186.2 kPa (3.0 to 27.0 psig)	
	kPa	psig	kPa	psig		kPa	psig	kPa	psig
0	20.7	3.0	20.7	3.0	60	70.3	10.2	120.0	17.4
10	29.0	4.2	37.3	5.4	70	78.6	11.4	136.6	19.8
20	37.2	5.4	53.8	7.8	80	86.9	12.6	153.1	22.2
30	45.5	6.6	70.4	10.2	90	95.2	13.8	169.7	24.6
40	53.8	7.8	86.9	12.6	100	103.4	15.0	186.2	27.0
50	62.1	9.0	103.5	15.0					

Table C-2. Input to Output I/P Converter Relationships (AV2)

% of Control Signal	I/P Converter			% of Control Signal	I/P Converter		
	Input	Output			Input	Output	
	mA	kPa	psig		mA	kPa	psig
0	4.0	20.7	3.0	60	13.6	70.3	10.2
10	5.6	29.0	4.2	70	15.2	78.6	11.4
20	7.2	37.2	5.4	80	16.8	86.9	12.6
30	8.8	45.5	6.6	90	18.4	95.2	13.8
40	10.4	53.8	7.8	100	20.0	103.4	15.0
50	12.0	62.1	9.0				

CAM SELECTION

In a system involving only a single actuator or cylinder, the B cam is probably satisfactory and should be tried first. However, one of the other cams may provide a more stable control over a wide range of operation within a given proportional band gain adjustment on the controller. Where the actuator or cylinder is part of a complex control system, the three standard cams A, B and C provide a choice of control characteristics. The cam, in conjunction with a span adjustment, are likely to meet the control characteristic required for the system.

Steps in selecting a standard cam for a particular application are:

1. With the B (linear) cam in place, determine and plot the actual controlled medium versus piston (or valve) position characteristic by manually adjusting valve position and measuring the controlled medium (Fig. C-4).

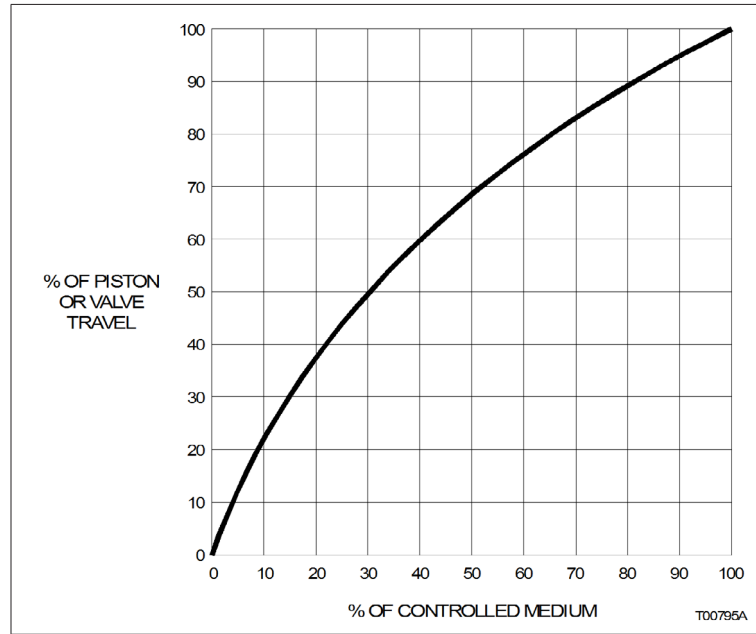

Figure C-4. Regulated Device Characteristics

2. Plot the exact control medium versus control signal characteristic given or desired for the application. This is usually a linear function (Fig. C-5).

NOTE: If angularity is introduced into the drive linkage, replot the controlled medium versus piston travel curves. In all cases, avoid overstroking the final control device.

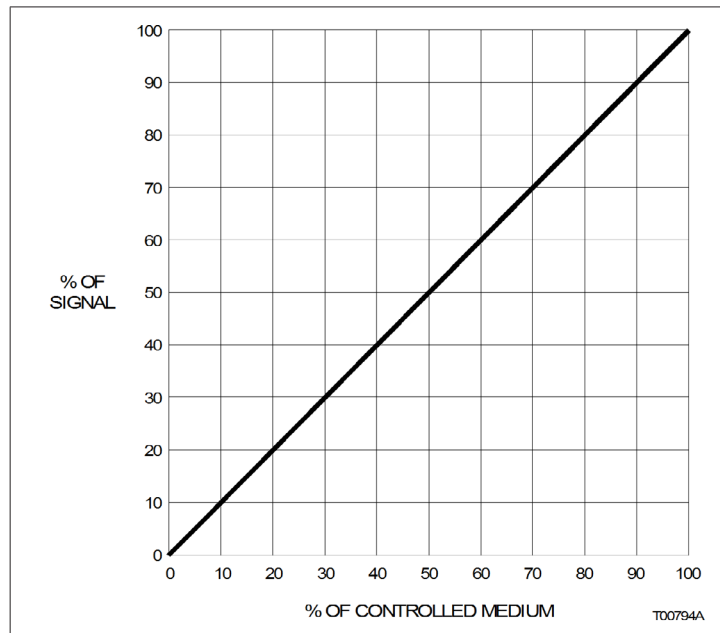

Figure C-5. Desired Control

3. Using values determined in Steps 1 and 2, plot a curve for the exact control signal versus piston (or valve) characteristic that will produce the results of Figure C-6 from a cylinder or actuator that performs as shown in Figure C-4. In the examples shown, the required curve is a mirror image of the Step 1 curve taken about the Step 2 curve (Fig. C-6).

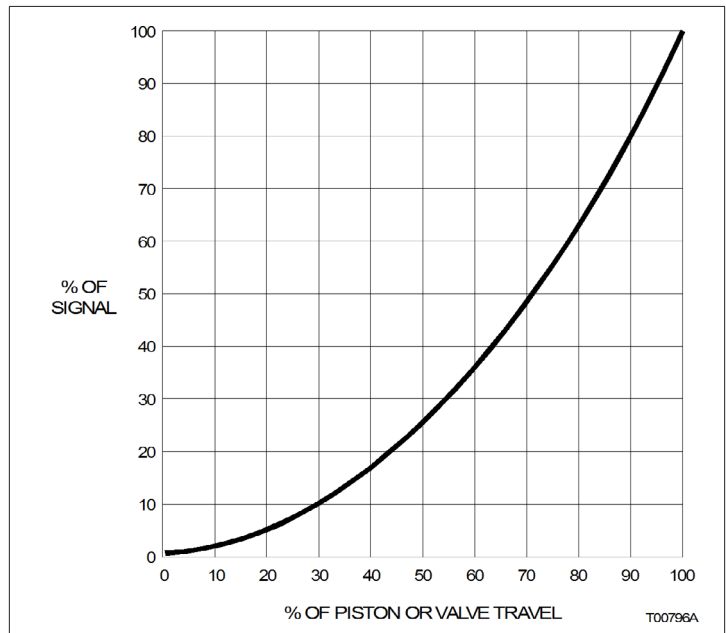

Figure C-6. Cam Characteristics

4. Compare the curve plotted in Step 3 with the cam curves shown in Figures C-1, C-2 and C-3. Select a standard cam shape (in this case a C cam) whose characteristic most closely matches the control signal versus piston (or valve) characteristic plotted in Step 3.
5. If necessary, adjust the positioner zero and span as outlined under **Zero Adjustment** and **Span Adjustment** in Section 4 to make the control signal pressure versus piston (or valve) characteristic conform better to the curve plotted in Step 3.
6. If the required characteristic cannot be obtained using this procedure, or if more exact characteristics are required, alter the shape of a standard A, B or C cam or cut a new cam from a blank cam as outlined under **CAM SHAPING**.

CAM SHAPING

To assist in the alteration process, a graph is imprinted on each cam. This graph consists of radial lines and concentric arcs. The first and last radial lines mark the angles at which zero and 100 percent of cam rotation occurs for control purposes; the radial

lines in between are equal intervals of rotation. These lines are indexes of percentage of piston (or valve) travel.

The concentric arcs on the cam correspond to actual control signal pressure values shown in Table C-1 for the particular positioner being used. Together, the radial lines and concentric arcs form a polar diagram on which a new cam shape (and characteristic) can be plotted.

NOTE: Before cutting any cam, make sure that shaping will involve removal of cam material and not building up of cam material. For example, if the characteristic plotted lies between the A and B cams (Figs. C-1 and C-2), cut the A cam away.

1. Use the cam selected in Step 4 under **CAM SELECTION**. Also have available a graph of control signal versus actuator travel for the characteristic desired. (Such a graph may be derived from the cam characteristic curve developed in Step 3 of **CAM SELECTION**). Replace the percent values on the vertical axis with the corresponding actual signal from Table C-1 for the positioner being used.
2. Refer to Figure C-7 for the method of transferring data from the graph to the cam. For each radial line on the cam (representing a percent piston or valve travel), find the value of signal on the graph that corresponds to that percent piston or valve travel. Proceed along the radial line to the concentric arc that represents the signal pressure for the radial lines percentage piston or valve travel. Mark the cam at that point.
3. Continue in this manner until all the radial lines are marked with a signal pressure point. For example: In Figure C-7, the graph calls for a signal of 10.4 milliamps at 60-percent travel position. On the 60-percent travel radial line of the cam, a mark is placed on concentric line four, representing that pressure.
4. Draw a line through the points located in Step 2. This will be the desired cam shape.

NOTE: If a cam shape has too steep a rise, the cam follower may become locked. A cam with too steep a rise may be replaced with a cam with a gentler rise if sufficient angularity is introduced into the drive linkage of the actuator or cylinder. Optional blank cams are available if alteration of the standard cam is not desired.

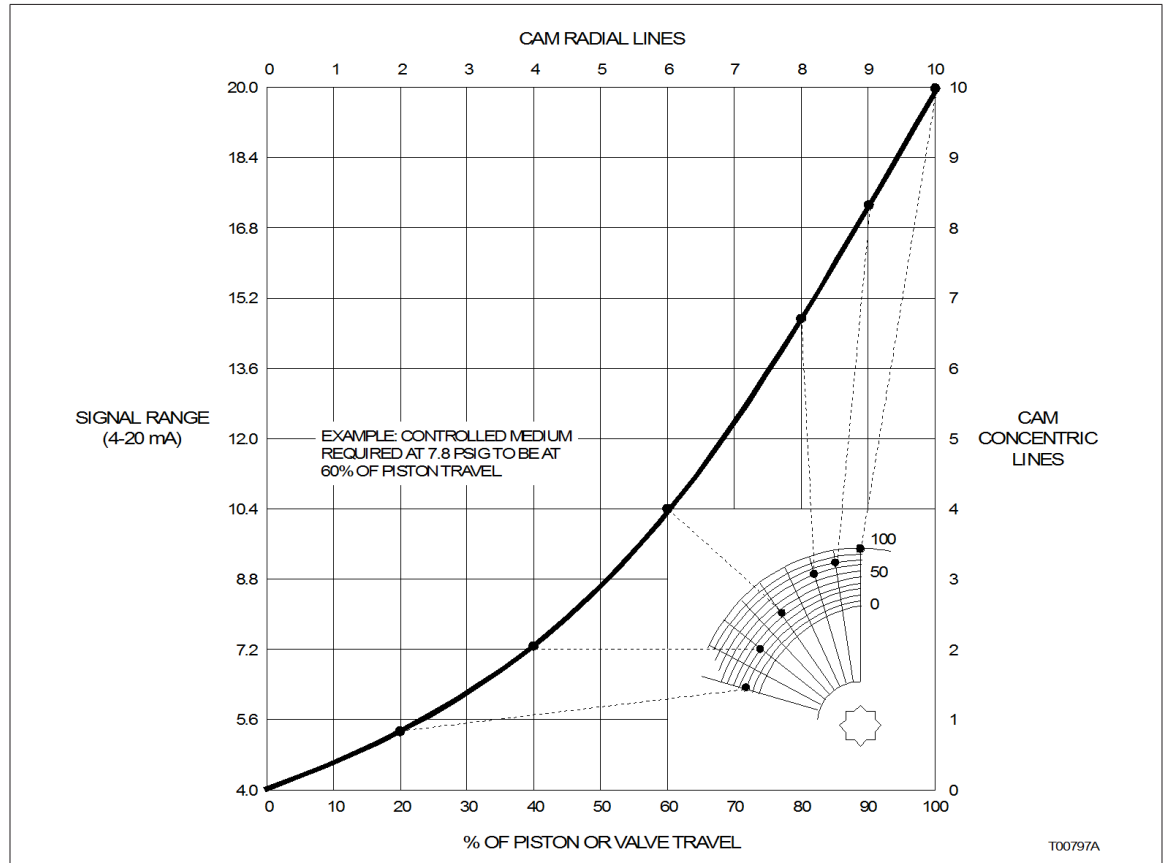

Figure C-7. Graph to Cam Data Transfer

APPENDIX D - TYPE AV1 PNEUMATIC POSITION TRANSMITTER

INTRODUCTION

This appendix covers the optional pneumatic position transmitter kit that is available for Type AV1 positioners. This option is only available for Type AV1__0__ positioners. The topics covered are:

- Description.
- Installation.
- Calibration.

DESCRIPTION

The Type AV1 positioner may be used as a position transmitter by generating a pneumatic signal that is a function of an input position. The same combinations of signal ranges and stroke spans are offered as in the positioner application. Those signal ranges and strokes are: 20.7 to 103.4-kilopascals (3.0 to 15.0-pounds per square inch gage), or 20.7 to 186.2-kilopascals (3.0 to 27.0-pounds per square inch gage) output for strokes from 25.4 to 101.6 millimeters (0.5 to 4.0 inches).

The output signal may be made a square root, linear or square function of the input position through the use of the A, B or C portion of the cam, respectively. Other characteristics may be created by shaping the cam ([Appendix C](#)).

The Type AV1 positioner functions as a position transmitter by interconnecting the I input signal with the 02 output port and tapping into this interconnection for the output signal. A plug is placed in the 01 port. The pneumatic position transmitter kit provides the necessary hardware ([Fig. D-1](#)). [Table D-1](#) lists the individual part numbers and quantities of the items identified in [Figure D-1](#).

A change in input (cam shaft position) causes a deflection of the range spring via the cam linkage. The resulting force imbalance between the signal diaphragm assembly and the range spring causes a change in the 02 output that is fed back to the signal diaphragm assembly.

The signal diaphragm assembly now acts as a feedback element by opposing the input force from the range spring. When the force from the 02 pressure in the signal diaphragm assembly equals the new range spring force, the output stabilizes and represents the desired function of the input position.

TYPE AV1 PNEUMATIC POSITION TRANSMITTER

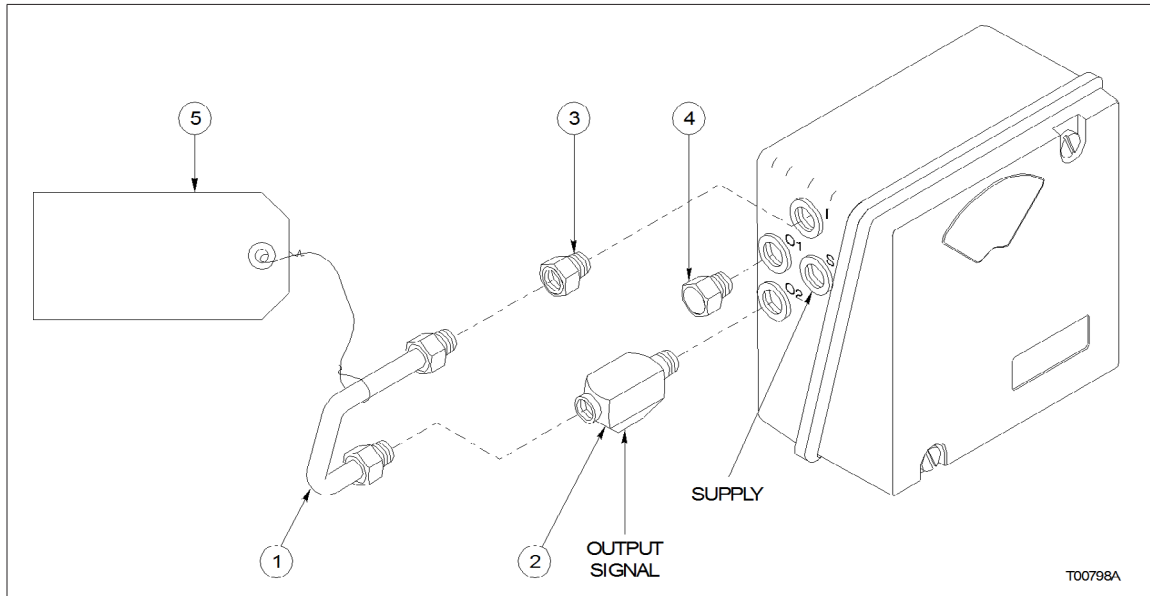

Figure D-1. Pneumatic Position Transmitter Kit

Table D-1. Pneumatic Position Transmitter Kit (258492_1)

Item Number	Part Number	Quantity	Description
1	5400307_2	1	Air line
2	¼ MRO-B	1	Street tee
3	195727_2	2	Brass nipple
4	¼-18 NPT	1	Brass pipe plug
5	—	1	Tag, warning

INSTALLATION

NOTE: This option is only available for Type AV1__0__ positioners.

Installation is similar to normal positioner installation ([Section 3](#)). The actuator should be coupled to the position transmitter cam shaft so as to cause a 90-degree rotation of the shaft for full travel of the device (or 45-degree for Type AV1_1__ positioners). For a linear motion device (i.e., diaphragm actuators), the cam shaft is driven by the drive arm and the connecting link as the positioner application. For a 90-degree rotation device, it may be desired to couple the cam shaft directly to the actuator. The zero position of the cam shaft can be adjusted in 45-degree increments by repositioning the cam on the shaft.

The direction of the transmitted signal can be reversed by placing the reverse acting cam, located on the inside of the positioner cover, on the cam shaft.

CALIBRATION

Make sure the position transmitter is at maximum gain (Table 4-1) prior to making any adjustments. The positioner comes with the maximum gain hinge spring installed from the factory.

The following description is based on a 20.7 to 103.4-kilopascal (3.0 to 15.0-pound per square inch gage) output for zero to 100-percent travel of the actuator.

1. Install an accurate pressure gage at the output connection (02 port).
2. Turn off the supply air.
3. Slowly stroke the actuator to its zero position.
4. Adjust the linkage between the transmitter and the actuator until the cam follower is aligned with the zero line on the cam (Fig. 3-8).
5. Slowly stroke the actuator to the 100% position.
6. Adjust the pivot position on the arm (Item 63, Fig. 9-3) or other external linkage until the cam follower is at 100% of cam rotation (radial line marked 100 on the cam).
7. Repeat Steps 3 through 6 until the cam follower is at 0% cam when the actuator is at 0% stroke and 100% cam when the actuator is at 100% stroke.
8. Turn on the air supply.
9. Move the actuator to the 0% stroke position.
10. If the output is not 20.7 kPa (3.0 psig), loosen the zero adjustment set screw on the zero adjustment nut (Fig. 4-1). Turn the zero adjustment nut (while keeping the eyebolt from rotating) until a 20.7-kPa (3.0-psig) output is achieved.
11. Tighten the zero adjustment set screw.
12. Move the actuator to the 100% stroke position.
13. If the output is not at 103.4 kPa (15.0 psig), loosen the span adjustment screw and move the span adjustment assembly (Fig. 4-1) along the cam follower arm until a 103.4-kPa (15.0-psig) reading is obtained.
14. Tighten the span adjustment screw.

15. Repeat Steps 8 through 14 until the positioner is calibrated.

NOTE: Moving the span adjustment assembly toward the valve body provides a longer actuator stroke for a given signal change (i.e., increases the range of travel for the cam follower arm). Moving the span adjustment bearing away from the valve body causes the opposite to occur (i.e., decreases the range of travel for the cam follower arm).

Index

Numerics

4 to 20 mA position transmitter.....	A-1
Calibration.....	A-6

A

Accessories	1-12
Accuracy.....	1-8
Air consumption.....	1-8
Air supply filtering.....	3-8
Air supply pressure.....	3-8
Air supply quality	3-9
Application.....	1-3
Automatic to manual operation.....	5-1

C

Calibration	4-1
4 to 20 mA position transmitter.....	A-6
Cam	4-3
Gain adjustment.....	4-5
Position transmitter	D-3
Potentiometric position transmitter	A-2
Short stroking.....	4-4
Span adjustment.....	4-3
Graph.....	4-5
Speed adjustment.....	4-5
Orifice.....	4-6
Pilot valve stroke.....	4-6
Split ranging.....	4-4
Tools	4-1
Troubleshooting	4-8
Zero adjustment.....	4-1
Graph.....	4-4
Zero suppression.....	4-4
Cam.....	3-7, 4-3
A - square root.....	3-6
B - linear	3-6
C - square.....	3-6
Characteristics.....	3-7
Characterization.....	C-1
Direct acting.....	3-6
Linear.....	1-2
Replacing.....	8-5
Reverse acting.....	3-6
Roller alignment.....	3-8, B-4
Selection	C-3
Shaping.....	C-5
Square	1-2
Square root	1-2
Capacity.....	1-8

D

Deadband.....	1-8
Description	1-1
Diaphragm assembly replacement.....	8-5
Direct acting	3-6
Direct coupling mounting.....	3-6, B-3
Double acting actuator tubing connections	3-14, B-8
Drive arm connections	3-4, B-4
Drive shaft variations.....	3-5

E

Electrical connections	3-4
Enclosure classification.....	1-8, 3-2
Equalizing valve	5-1
Explosionproof I/P converter	1-3

F

Features.....	1-3
Filtering air supply.....	3-8
Filters	3-9

G

Gage block	1-2
Gain.....	1-8, 4-5
Gain adjustment.....	4-5
Gain hinge spring	
Replacing	8-2
Gain hinge springs	4-5
Grounding	3-11

H

Hinge springs	4-5
How to use this instruction	1-5
Humidity limits	1-9
Hysteresis	1-8

I

I/P assembly replacement.....	8-4
Input impedance.....	1-7
Input range	1-7
Inspection.....	3-1
Installation	
Cam.....	3-7
Cam characteristics.....	3-7
Cam roller alignment	3-8, B-4
Electrical connections.....	3-4
Enclosure classification	3-2

Index (continued)

Mounting.....	3-4
Direct coupling.....	3-6, B-3
Drive arm connections.....	3-4, B-4
Drive shaft variations.....	3-5
Linkage.....	3-5, B-3
Mounting considerations.....	3-2
Mounting dimensions, explosionproof.....	3-3
Mounting dimensions, standard.....	3-3
Position transmitter.....	D-2
Tubing.....	3-8
Air supply filtering.....	3-8
Air supply pressure.....	3-8
Air supply quality.....	3-9
Port locations.....	3-9, B-5
Tubing connections.....	3-9
Double acting actuator.....	3-14, B-8
Single acting actuator ..	3-11, 3-12, 3-13, B-6, B-7
Unpacking and inspection.....	3-1
Wiring.....	3-10, 3-13
Grounding.....	3-11
Instruction content.....	1-5
Intended user.....	1-1

L

Linearity.....	1-8
Linkage mounting.....	3-5, B-3

M

Maintenance.....	7-1
Maintenance schedule.....	7-1
Manifold.....	1-2, 5-1
Filters.....	3-9
Replacing.....	8-1
Manual to automatic operation.....	5-1
Materials of construction.....	1-8
Mounting.....	3-4
Considerations.....	3-2
Dimensions, explosionproof.....	3-3
Dimensions, standard.....	3-3
Direct coupling.....	3-6, B-3
Drive arm connections.....	3-4, B-4
Drive shaft variations.....	3-5
Linkage.....	3-5, B-3

N

NEMA 4X.....	1-3
Nomenclature.....	1-6, B-1

O

Orifice.....	4-6
--------------	-----

P

Performance series.....	1-2
Pilot valve.....	
High gain.....	1-2
Performance series.....	1-2
Replacing.....	8-4
Stroke adjustment.....	4-6, 8-7
Pneumatic connections.....	1-8
Port locations.....	3-9, B-5
Position transmitter.....	
4 to 20 mA.....	A-1
Calibration.....	A-6
Calibration.....	D-3
Description.....	D-1
Installation.....	D-2
Kit.....	D-2
Potentiometric.....	A-1
Calibration.....	A-2
Positioner.....	
Specifications.....	1-7
Accuracy.....	1-8
Air consumption.....	1-8
Capacity.....	1-8
Deadband.....	1-8
Enclosure classification.....	1-8
Gain.....	1-8
Humidity limits.....	1-9
Hysteresis.....	1-8
Input impedance.....	1-7
Input range.....	1-7
Linearity.....	1-8
Materials of construction.....	1-8
Pneumatic connections.....	1-8
Repeatability.....	1-8
Resolution.....	1-8
Standard stroke range.....	1-8
Supply pressure.....	1-8
Supply pressure effect.....	1-8
Temperature limits.....	1-9
Vibration effect.....	1-8
Weight.....	1-9
Positioner errors.....	6-1
Positioner features.....	1-3
Potentiometric position transmitter.....	A-1
Calibration.....	A-2
Pressure.....	3-8
Preventive maintenance.....	7-1

Index (continued)

Q	
Quick start	B-1
Calibration.....	B-11
Mounting.....	B-2
Tubing.....	B-5
Wiring.....	B-8

R	
Radio frequency interference (RFI)	3-15
Reference documents	1-6
Repeatability.....	1-8
Replacement procedures	8-1
Replacing	
Cam	8-5
Diaphragm assembly.....	8-5
Gain hinge spring.....	8-2
I/P assembly	8-4
Manifold	8-1
Pilot valve assembly	8-4
Resolution.....	1-8
Reverse acting.....	3-6

S	
Short stroking	4-4
Graph.....	4-5
Single acting actuator tubing connections.....	3-11, 3-12, 3-13, B-6, B-7
Span adjustment.....	4-3
Graph.....	4-5
Short stroking.....	4-4
Split ranging.....	4-4
Spare parts	
Additional.....	9-3
Specifications	
Positioner.....	1-7
Accuracy	1-8
Air consumption	1-8
Capacity	1-8
Deadband	1-8
Enclosure classification.....	1-8
Gain	1-8
Humidity limits.....	1-9
Hysteresis	1-8
Input impedance	1-7
Input range.....	1-7
Linearity	1-8
Materials of construction	1-8
Pneumatic connections.....	1-8
Repeatability	1-8
Resolution	1-8

Standard stroke range	1-8
Supply pressure.....	1-8
Supply pressure effect.....	1-8
Temperature limits	1-9
Vibration effect.....	1-8
Weight.....	1-9

Speed.....	4-5
Speed adjustment	
Orifice	4-6
Pilot valve stroke	4-6
Split ranging	4-4
Graph	4-5
Stroke adjustment, pilot valve	8-7
Stroke range, standard.....	1-8
Supply pressure	1-8
Supply pressure effect	1-8

T	
Temperature limits	1-9
Troubleshooting	6-1
Positioner errors	6-1
Troubleshooting calibration	4-8
Tubing	3-8
Air supply filtering	3-8
Air supply pressure.....	3-8
Air supply quality	3-9
Connections	3-9
Double acting actuator.....	3-14, B-8
Port locations.....	3-9, B-5
Single acting actuator ..	3-11, 3-12, 3-13, B-6, B-7

U	
Unpacking	3-1

V	
Vibration effect	1-8

W	
Weight	1-9
Wiring	
AV1.....	3-13
AV2.....	3-10
Grounding.....	3-11
Wiring requirements	3-15

Z	
Zero adjustment	4-1
Graph	4-4

Index (continued)

Zero suppression.....	4-4
Zero suppression	4-4
Graph	4-4
